

SERVICE MANUAL
AC Power Source/Analyzers
HP Models 6811A, 6812A, and 6813A
6811B, 6812B, and 6813B
Harmonic/Flicker Test Systems
HP Models 6841A and 6842A

For instruments with Serial Numbers:

HP 6811A: US37290101 and up
HP 6811B: US38390101 and up
HP 6812A: US37290101 and up
HP 6812B: US38390101 and up
HP 6813A: US37290101 and up
HP 6813B: US38390101 and up
HP 6841A: US37340101 and up
HP 6842A: US37340101 and up

For instruments with higher serial numbers, a change page may be included.

HP Part No. 5962-0859
Microfiche No 6962-0860



Printed in U.S.A.
January, 1999
Last online update November, 1999

Warranty Information

CERTIFICATION

Hewlett-Packard Company certifies that this product met its published specifications at time of shipment from the factory. Hewlett-Packard further certifies that its calibration measurements are traceable to the United States National Bureau of Standards, to the extent allowed by the Bureau's calibration facility, and to the calibration facilities of other International Standards Organization members.

WARRANTY

This Hewlett-Packard hardware product is warranted against defects in material and workmanship for a period of three years from date of delivery. HP software and firmware products, which are designated by HP for use with a hardware product and when properly installed on that hardware product, are warranted not to fail to execute their programming instructions due to defects in material and workmanship for a period of 90 days from date of delivery. During the warranty period Hewlett-Packard Company will, at its option, either repair or replace products which prove to be defective. HP does not warrant that the operation for the software firmware, or hardware shall be uninterrupted or error free.

For warranty service, with the exception of warranty options, this product must be returned to a service facility designated by HP. Customer shall prepay shipping charges by (and shall pay all duty and taxes) for products returned to HP for warranty service. Except for products returned to Customer from another country, HP shall pay for return of products to Customer.

Warranty services outside the country of initial purchase are included in HP's product price, only if Customer pays HP international prices (defined as destination local currency price, or U.S. or Geneva Export price).

If HP is unable, within a reasonable time to repair or replace any product to condition as warranted, the Customer shall be entitled to a refund of the purchase price upon return of the product to HP.

LIMITATION OF WARRANTY

The foregoing warranty shall not apply to defects resulting from improper or inadequate maintenance by the Customer, Customer-supplied software or interfacing, unauthorized modification or misuse, operation outside of the environmental specifications for the product, or improper site preparation and maintenance. NO OTHER WARRANTY IS EXPRESSED OR IMPLIED. HP SPECIFICALLY DISCLAIMS THE IMPLIED WARRANTIES OF MERCHANTABILITY AND FITNESS FOR A PARTICULAR PURPOSE.

EXCLUSIVE REMEDIES

THE REMEDIES PROVIDED HEREIN ARE THE CUSTOMER'S SOLE AND EXCLUSIVE REMEDIES. HP SHALL NOT BE LIABLE FOR ANY DIRECT, INDIRECT, SPECIAL, INCIDENTAL, OR CONSEQUENTIAL DAMAGES, WHETHER BASED ON CONTRACT, TORT, OR ANY OTHER LEGAL THEORY.

ASSISTANCE

The above statements apply only to the standard product warranty. Warranty options, extended support contacts, product maintenance agreements and customer assistance agreements are also available. Contact your nearest Hewlett-Packard Sales and Service office for further information on HP's full line of Support Programs.

Safety Summary

GENERAL -

This is a Safety Class 1 instrument (provided with a terminal for connection to protective earth ground).

OPERATION - BEFORE APPLYING POWER:

Verify that the product is set to match the available line voltage, the correct line fuse is installed, and all safety precautions (see following warnings) are taken. In addition, note the instrument's external markings described under "Safety Symbols"

WARNING -

Servicing instructions are for use by service-trained personnel. To avoid dangerous electrical shock, do not perform any servicing unless you are qualified to do so.

Before switching on the instrument, the protective earth terminal of the instrument must be connected to the protective conductor of the (mains) power cord. The mains plug shall be inserted only in an outlet socket that is provided with a protective earth contact. This protective action must not be negated by the use of an extension cord (power cable) that is without a protective conductor (grounding). Grounding one conductor of a two-conductor outlet is not sufficient protection.

If this instrument is to be energized via an auto-transformer (for voltage change), make sure the common terminal is connected to the earth terminal of the power source.

Any interruption of the protective (grounding) conductor or disconnection of the protective earth terminal will cause a potential shock hazard that could result in personal injury.

Whenever it is likely that the protective earth connection has been impaired, this instrument must be made inoperative and be secured against any unintended operation.

Only fuses with the required rated current, voltage, and specified type (normal blow, time delay, etc.) should be used. Do not use repaired fuses or short-circuited fuseholders. To do so could cause a shock or fire hazard.

Do not operate this instrument in the presence of flammable gases or fumes.

Do not install substitute parts or perform any unauthorized modification to the instrument.

Some procedures described in this manual are performed with power supplied to the instrument while its protective covers are removed. If contacted, the energy available at many points may result in personal injury.

Any adjustment, maintenance, and repair of this instrument while it is opened and under voltage should be avoided as much as possible. When this is unavoidable, such adjustment, maintenance, and repair should be carried out only by a skilled person who is aware of the hazard involved.



















Capacitors inside this instrument may hold a hazardous charge even if the instrument has been disconnected from its power source.

SAFETY SYMBOLS

Refer to the table on the following page

WARNING The WARNING sign denotes a hazard. It calls attention to a procedure, practice, or the like, which, if not correctly performed or adhered to, could result in personal injury. Do not proceed beyond a WARNING sign until the indicated conditions are fully understood and met.

Caution The CAUTION sign denotes a hazard. It calls attention to an operating procedure, or the like, which, if not correctly performed or adhered to, could result in damage to or destruction of part or all of the product. Do not proceed beyond a CAUTION sign until the indicated conditions are fully understood and met.

Safety Symbol Definitions			
Symbol	Description	Symbol	Description
	Direct current		Terminal for Line conductor on permanently installed equipment
	Alternating current		Caution, risk of electric shock
	Both direct and alternating current		Caution, hot surface
	Three-phase alternating current		Caution (refer to accompanying documents)
	Earth (ground) terminal		In position of a bi-stable push control
	Protective earth (ground) terminal (Intended for connection to external protective conductor.)		Out position of a bi-stable push control
	Frame or chassis terminal		On (supply)
	Terminal for Neutral conductor on permanently installed equipment		Off (supply)
	Terminal is at earth potential (Used for measurement and control circuits designed to be operated with one terminal at earth potential.)		Standby (supply) Units with this symbol are not completely disconnected from ac mains when this switch is off. To completely disconnect the unit from ac mains, either disconnect the power cord or have a qualified electrician install an external switch.

Notice

Hewlett-Packard shall not be liable for errors contained herein or for incidental or consequential damages in connection with the furnishing, performance or use of this material.

This document contains proprietary information which is protected by copyright. All rights are reserved. No part of this document may be photocopied, reproduced, or translated into another language without the prior written consent of Hewlett-Packard Company. The information contained in this document is subject to change without notice.

© Copyright 1995, 1997, 1999 Hewlett-Packard Company

Printing History

First EditionOctober, 1995

Second Edition July, 1997

Third Edition January, 1999

Table of Contents

Warranty Information	2
Safety Summary	3
Notice	4
Printing History	4
Table of Contents	5
Figures and Tables	7
1 INTRODUCTION	9
Organization	9
Safety Considerations	9
Related Documents	9
Revisions	10
Instrument Identification	10
Manual Revisions	10
Firmware Revisions	10
Electrostatic Discharge	10
2 PERFORMANCE TESTS	11
Introduction	11
Test Equipment Required	11
Current Monitoring Resistor	12
Constant Voltage Tests	12
Procedures	13
3 PRINCIPLES OF OPERATION	19
Introduction	19
General Description	19
A1 Front Panel Assembly	19
A2 HP-IB / RS-232 Interface Assembly	20
A3 FET Assembly	20
A4 AC Input Assembly	20
A5 DC Rail Assembly	20
A6 Bias Assembly	21
A7 Inverter Assembly	21
A8 Digital Signal Processing (DSP) Assembly	21
A9 Output / Filter Assembly	21
A10 Control Assembly	22
A11 Trigger (BNC) Assembly	22

4 TROUBLESHOOTING	23
Introduction	23
Test Equipment Required	23
Troubleshooting Hints	23
Power-on Self-test Failures	24
Run-Time Errors	24
Overall Troubleshooting Flowchart	26
A1 Front Panel Assembly Troubleshooting	28
A2 HP-IB/RS-232 Board Troubleshooting	28
A3 FET Board Troubleshooting	29
A5 DC Rail Assembly Troubleshooting	31
A6 Bias Assembly Troubleshooting	33
A7 Inverter Assembly Troubleshooting	35
Slow-Start Procedure	39
A8 DSP and A10 Control Assembly Troubleshooting	40
A9 Output/Filter/Relay Assembly Troubleshooting	43
A11 Trigger/BNC Board Troubleshooting	44
Initialization	46
ROM Upgrade	46
Identifying the Firmware	46
Upgrade Procedure	46
Post-repair Calibration	47
Inhibit Calibration Switch	47
Disassembly Procedures	48
List of Required Tools	49
Top Cover (outer cover) Removal	49
Inner Top Cover Removal	49
A1 Front Frame / Panel Assembly Removal and Replacement	49
A2 HI-IB / RS 232 Board Removal and Replacement	50
A3 AC FET Assembly Removal and Replacement	50
A4 AC Input Board Removal and Replacement	50
A5 DC Rail Board Removal and Replacement	50
A6 Bias Board Removal and Replacement	51
A7 Inverter Assembly Removal and Replacement	51
A8 DSP Board and A10 Control Board Removal and Replacement	51
A11 Trigger (BNC) Board Removal and Replacement	52
A9 Output Board Removal and Replacement	52
5 REPLACEABLE PARTS LIST	53
Introduction	53
Reading the Tables	53
How to Order Parts	53
6 DIAGRAMS	67
Introduction	67
General Schematic Notes	67
INDEX	121

Figures and Tables

Figure 2-1. Test Setup	12
Figure 3-1. AC Power Source/Analyzer Block Diagram	22
Figure 4-1. Overall Troubleshooting Procedures (2 sheets)	26
Figure 4-2. Front Panel Assembly Troubleshooting	28
Figure 4-3. FET Assembly Test Waveforms	30
Figure 4-4. DC Rail Assembly Troubleshooting	31
Figure 4-5. DC Rail Assembly - Test Waveforms	32
Figure 4-6. Bias Assembly Voltage Distribution	34
Figure 4-7. Inverter Assembly Troubleshooting (2 sheets)	35
Figure 4-8. Inverter Assembly - Test Waveforms (2 sheets)	37
Figure 4-9. Output/Filter/Relay Troubleshooting	41
Figure 4-10. Trigger/BNC Board - Test Waveforms	43
Figure 4-11. Calibration Switches	45
Figure 4-12. Component Locations	46
Figure 6-1. Interconnect Diagram	66
Figure 6-2. Front Panel Assembly, Component Locations	67
Figure 6-3. Front Panel Assembly, Schematic Diagram (2 sheets)	68
Figure 6-4. HP-IB Assembly, Component Locations	70
Figure 6-5. HP-IB Assembly, Schematic Diagram	71
Figure 6-6. FET Assembly, Component Locations	72
Figure 6-7. FET Assembly, Schematic Diagram	73
Figure 6-8. AC Input Assembly, Component Locations	74
Figure 6-9. AC Input Assembly, Schematic Diagram	75
Figure 6-10. DC Rail/Diode Assembly, Component Locations (2 sheets)	76
Figure 6-11. DC Rail/Diode Assembly, Schematic Diagram (3 sheets)	78
Figure 6-12. Bias Assembly, Component Locations	81
Figure 6-13. Bias Assembly, Schematic Diagram (2 sheets)	82
Figure 6-14. Inverter Assembly, Component Locations	84
Figure 6-15. Inverter Assembly, Schematic Diagram (4 sheets)	85
Figure 6-16. DSP Assembly, Component Locations (2 sheets)	89
Figure 6-17. DSP Assembly, Schematic Diagram (10 sheets)	91
Figure 6-18. Control Board, Component Locations (2 sheets)	101
Figure 6-19. Control Assembly, Schematic Diagram (7 sheets)	103
Figure 6-20. Output Board, Component Locations	110
Figure 6-21. Output Assembly, Schematic Diagram (4 sheets)	111
Figure 6-22. Trigger Board, Component Locations	115
Figure 6-23. Trigger Assembly, Schematic Diagram	116
Figure 6-24. Thermistor Assembly, Component Locations	117
Figure 6-25. Thermistor Assembly, Schematic Diagram	117
Figure 6-26. Transformer Assembly, Component Locations	117
Figure 6-27. Thermistor Assembly, Schematic Diagram	117
Table 2-1. Test Equipment Required for Verification and Performance Tests	11
Table 2-2. Voltage Programming and Readback Accuracy	13
Table 2-3. Constant Voltage Load Effect	13
Table 2-4. Constant Voltage Source Effect	14
Table 2-5. RMS Current Accuracy Test	14
Table 2-6. Harmonic Distortion Test	15
Table 2-7. Frequency Accuracy Test	15
Table 2-8. DC Voltage Programming and Readback Accuracy	15
Table 2-9. Performance Test Record - HP 6811A/B	16
Table 2-10. Performance Test Record - HP 6812A/B, 6841A	17
Table 2-11. Performance Test Record - HP 6813A/B, 6842A	18

Table 2-10. Performance Test Record - HP 6812A/B, 6841A	17
Table 2-11. Performance Test Record - HP 6813A/B, 6842A	18
Table 4-1. Test Equipment Requirements for Troubleshooting	23
Table 4-2. Self-Test Errors	24
Table 4-3. Run-Time Errors	25
Table 4-4. HP-IB/RS232 Board Troubleshooting	28
Table 4-5. FET Board Troubleshooting	29
Table 4-6. Bias Assembly Troubleshooting	33
Table 4-7. DSP/Control Assembly Troubleshooting	39
Table 4-8. Voltage Measurements at J822 (viewed from circuit side of A10 control board)	40
Table 4-9. Voltage Measurements at J821 (viewed from circuit side of A10 control board)	40
Table 4-10. Trigger/BNC Board Troubleshooting	42
Table 5-1. Parts List for HP 6811A/B, 6812A/B, 6813A/B, 6841A, 6842A Main Assembly	52
Table 5-2. Parts List for HP 6811A/B, 6812A/B, 6813A/B, 6841A, 6842A Technical Manuals	54
Table 5-3. Parts List for HP 6811A/B, 6812A/B, 6813A/B, 6841A, 6842A AC Input Board	54
Table 5-4. Parts List for HP 6811A/B, 6812A/B, 6813A/B, 6841A, 6842A Bias Board	55
Table 5-5. Parts List for HP 6811A/B, 6812A/B, 6813A/B, 6841A, 6842A Inverter Board	56
Table 5-6. Parts List for HP 6811A/B, 6812A/B, 6813A/B, 6841A, 6842A FET Board	58
Table 5-7. Parts List for HP 6811A/B, 6812A/B, 6813A/B, 6841A, 6842A DC RAIL Board	59
Table 5-8. Parts List for HP 6811A/B, 6812A/B, 6813A/B, 6841A, 6842A Output Board	62
Table 5-9. Parts List for HP 6811A/B, 6812A/B, 6813A/B, 6841A, 6842A Control Board	64
Table 5-10. Parts List for HP 6811A/B, 6812A/B, 6813A/B, 6841A, 6842A Front Panel	64
Table 5-11. Parts List for HP 6811A/B, 6812A/B, 6813A/B, 6841A, 6842A DSP Board	64
Table 5-12. Parts List for HP 6811A/B, 6812A/B, 6813A/B, 6841A, 6842A Thermistor Board	64

Introduction

Organization

This manual contains information for troubleshooting and repairing to the component level models HP 6811A/B, 6812A/B, and 6813A/B Power Source/Analyzers, and models HP 6841A and 6842A Harmonic Flicker Test Systems. All models will hereafter be referred to as the ac source. This manual is organized as follows:

Chapter 1	Introduction
Chapter 2	Performance tests
Chapter 3	Principles of operation on a block-diagram level
Chapter 4	Troubleshooting
Chapter 5	Replaceable parts
Chapter 6	Diagrams

Safety Considerations

This ac power source is a Safety Class I instrument, which means it has a protective earth terminal. This terminal must be connected to earth ground through a power source equipped with a 4-wire (3-wire for HP 6811A/B), ground receptacle. Refer to the "Safety Summary" page at the beginning of this manual for general safety information. Before operation or repair, check the ac source and review this manual for safety warnings and instructions. Safety warnings for specific procedures are located at appropriate places in the manual.

WARNING: **Hazardous voltages exist within the ac power source chassis, at the output terminals, and at the analog programming terminals. Only qualified personnel who have been trained in working with high voltage power equipment are to service this unit.**

Related Documents

The following documents are shipped with your ac source:

- a Quick-Start Guide, to help you quickly get started using the ac source
- a User's Guide, containing detailed installation, checkout, and front panel information
- a Programming Guide, containing detailed HP-IB programming information
- a Quick Reference Card, designed as a memory jogger for the experienced user

Revisions

Instrument Identification

The ac source is identified by a 10-digit serial number. The items in this serial number are explained as follows:

- US** The first two letters indicates the country of manufacture, where US = USA.
- 3729** This is a code that identifies either the date of manufacture, or the date of a significant design change.
- 0101** The last four digits are a unique number assigned to each unit.

Manual Revisions

This manual was written for ac sources that have the same or higher serial numbers as those listed on the title page.

NOTE: If the serial number of your unit is higher than that shown on the title page, your unit was made after the publication of this manual and may have hardware or firmware differences not covered in this manual. If they are significant to the operation and/or servicing of the ac source, those differences are documented in one or more Manual Change sheets included with this manual.

 If the serial number of your unit is lower than those shown on the title page, your unit was made before the publication of this manual and can be different from that described here. The previous versions of this manual (print date October, 1995 or July, 1997) applies to these units.

Firmware Revisions

You can obtain the firmware revision number by either reading the integrated circuit label, or query the ac source using the HP-IB *IDN?' query command (see chapter 4, Troubleshooting).

Electrostatic Discharge

CAUTION: The ac source has components that can be damaged by ESD (electrostatic discharge). Failure to observe standard antistatic practices can result in serious degradation of performance, even when an actual failure does not occur.

When working on the ac source, observe all standard, antistatic work practices. These include, but are not limited to:

Working at a static-free station such as a table covered with static-dissipative laminate or with a conductive table mat (HP P/N 9300-0797, or equivalent).

Using a conductive wrist strap, such as HP P/N 9300-0969 or 9300-0970.

Grounding all metal equipment at the station to a single common ground.

Connecting low-impedance test equipment to static-sensitive components only when those components have power applied to them.

Removing power from the ac source before removing or installing printed circuit boards.

Performance Tests

Introduction

This chapter provides test procedures for checking the operation of a model HP 6811AB, 6812A/B, 6813A/B AC Power Source/Analyzer and HP 6841A, 6842A Harmonic/Flicker Test System. The required test equipment is specified and sample performance test record sheets are included. Instructions are given for performing the tests using the front panel keypad.:

Test Equipment Required

Table 2-1 lists the equipment required to perform the performance tests in this chapter. A test record sheet with specification limits and measurement uncertainties (when test using the recommended test equipment) may be found at the back of this section.

WARNING: SHOCK HAZARD. These tests should only be performed by qualified personnel. During the performance of these tests, hazardous voltages may be present at the output of the unit.

Table 2-1. Test Equipment Required for Verification and Performance Tests

Type	Specifications	Recommended Model
Digital Voltmeter	Resolution: 10 nV @ 1V Readout: 8 1/2 digits Accuracy: 20 ppm	HP 3458A
Current Monitor	0.01 ohms +/-200 ppm 10 Watts	Guildline 7320/15
Audio Analyzer	Input Voltage: 50mV TO 300V Distortion Accuracy: +/-1db 20Hz to 20khz Residual Distortion/Noise: -80db (0.01%) 20Hz to 20kHz	HP 8903A
Frequency Counter	Accuracy @ 1 kHz < 0.001%	HP 5316B
Ratio Transformer ¹	30:1 ratio < 50 ppm	
Variable-Voltage Transformer	Power: 1 Phase 3.4KVA Range: 104-127V 47-63 Hz / 207-253V 47-63 Hz	Superior Powerstat
Load Resistors	20 ohms, 5 A, 1000 W minimum 250 ohms, 2 A, 500 W minimum 120 ohms, 2.5 A, 750 W minimum 51 ohms, 6 A, 1800 W minimum	
HP-IB Controller	Full HP-IB capabilities	HP Series 300 or equivalent

¹A 30:1 ratio transformer is not required for a valid MIL-STD-5622A test. The 30:1 ratio transformer is only required when a 4:1 test equipment ratio is desired using the HP 3458A voltmeter in the 1000 volt range.

2 - Performance Tests

Current Monitoring Resistor

A 4-terminal current monitoring resistor (current shunt) listed in Table 2-1 is required to eliminate output current measurement error caused by voltage drops in the load leads and connections.

Constant Voltage Tests

If more than one meter or a meter and an oscilloscope are used, connect each to the sense terminals by separate leads to avoid mutual coupling effects.

Tables 2-2 through 2-8 provide the test procedures for verifying the 6811A/B, 6812A/B, 6813A/B, and the 6841A, 6842A compliance with the specifications given in Appendix A of the User's Guide. Please refer to the CALIBRATION PROCEDURE or TROUBLESHOOTING if you observe out-of specification performance. The performance test specifications are listed in the Performance Test Records at the end of this chapter. You can record the actual measured values in the columns provided. When performing the load tests select an adequate gauge wire using the procedures given in the User's Guide for connecting the load.

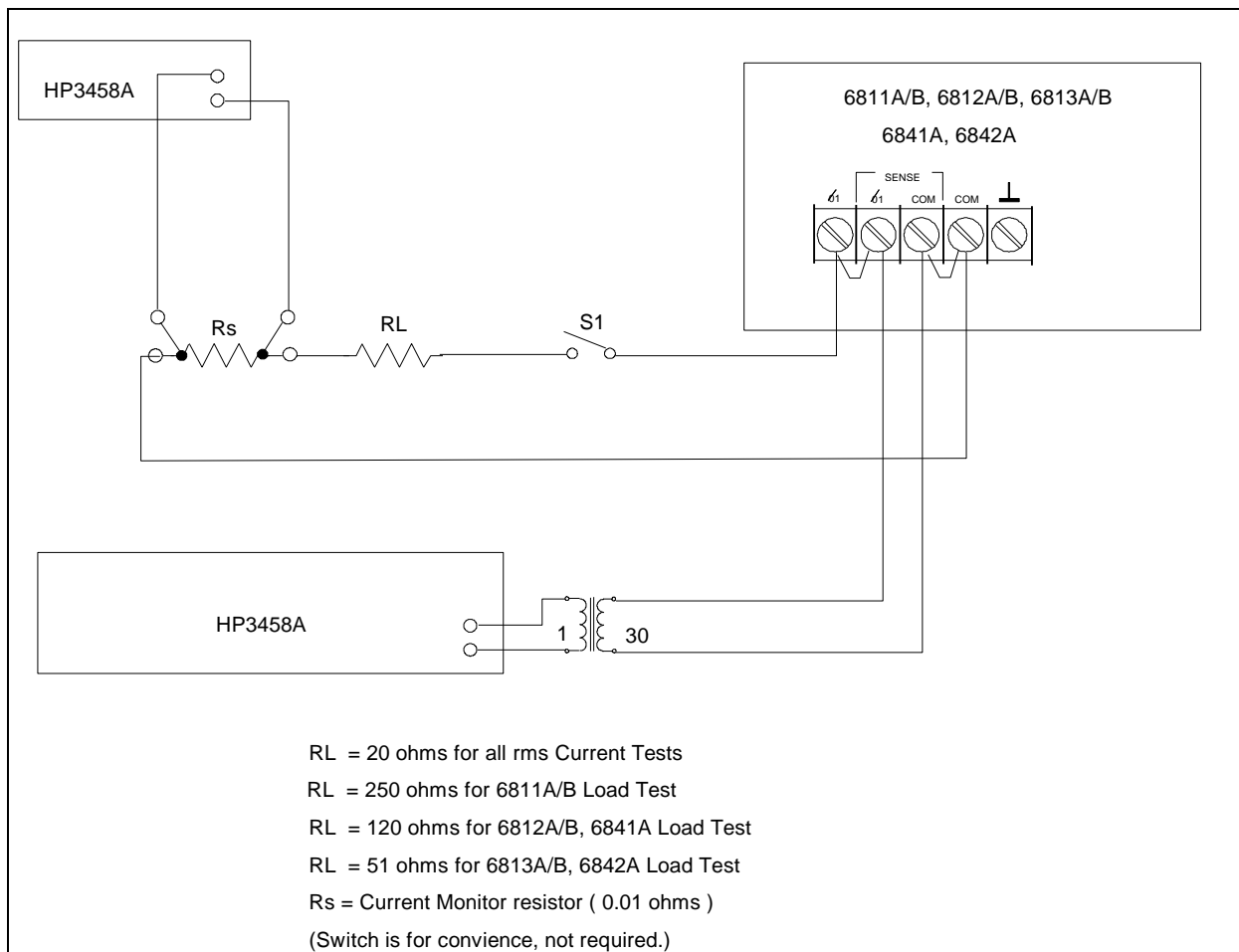

Figure 2-1. Test Setup

Procedures

In the following procedures the term "UUT" means "unit under test" which can be either the 6811A/B, 6812A/B, 6813A/B, 6841A, or 6842A AC Source.

Table 2-2. Voltage Programming and Readback Accuracy

Step	Action	Normal Result
This procedure verifies that the voltage programming / HPIB readback and Front Panel display functions are within specifications.		
1	Turn off the UUT and connect DVM and Ratio Transformer as shown in Test Setup Figure 2-1. Switch S1 is open.	
2	Turn on the UUT. Recall factory defaults with *RST then program output to VOLT 300, FREQ 45, SHAPE:SIN	CV annunciator on Output current near zero
3	Record voltage readings at DMM and on front panel display.	Reading within specified high range 300V / 45Hz limits
4	Program FREQ 400	
5	Record voltage readings at DMM and on front panel display.	Reading within specified high range 300V / 400Hz limits
6	Program FREQ 1000, CURR:PEAK 40	
7	Record voltage readings at DMM and on front panel display.	Reading within specified high range 300V / 1KHz limits

Table 2-3. Constant Voltage Load Effect

Step	Action	Normal Result
This test measures the change in output voltage resulting from a change in output current from full-load to no-load or no-load to full-load.		
1	Turn off the UUT and connect DMM, Load Resistors, Current shunt and Ratio Transformer as shown in Test Setup Figure 2-1 with S1 closed.	
2	Turn on the UUT. Recall factory defaults with *RST. Set ALC:DET RMS to rms then program output to VOLT 300, FREQ 60, SHAPE:SIN	CV annunciator on, output current near: 1.2 amps for 6811A/B 2.5 amps for 6812A/B 5.8 amps for 6813A/B
3	Record voltage reading of DMM.	
4	Open S1	Output current near zero.
5	Record voltage readings at DMM.	
6	Check test results	The difference between the DMM readings in Step 3 & 5 are within specified load effect limits.

2 - Performance Tests

Table 2-4. Constant Voltage Source Effect

Step	Action	Normal Result
This test measures the change in output voltage resulting from a change in AC Mains Input voltage from minimum to maximum value within the line voltage specification.		
1	Turn off the UUT and connect DMM, Load Resistors, Current shunt and Ratio Transformer as shown in Test Setup Figure 2-1 with S1 closed.	
2	Connect UUT AC input through a variable voltage transformer	
3	Turn on the UUT. Recall factory defaults with *RST. Set ALC:DET RMS to rms then program output to VOLT 300, FREQ 60, SHAPE:SIN,	CV annunciator on, output current near: 1.2 amps for 6811A/B 2.5 amps for 6812A/B, 6841A 5.9 amps for 6813A/B, 6842A
4	Adjust variable voltage transformer to low line condition (104 or 207 VAC)	
5	Record voltage reading of DMM.	
6	Adjust variable voltage transformer to high line condition (127 or 253 VAC)	
7	Record voltage readings at DMM.	
8	Check test results	The difference between the DMM readings in Step 3 & 5 are within specified line effect limits.

Table 2-5. RMS Current Accuracy Test

Step	Action	Normal Result
This test verifies the measurement accuracy of the rms current readback.		
1	Turn off the UUT and connect an 20 ohm Load Resistor, current shunt and DMM as shown in Test Setup Figure 2-1 with S1 closed.	
2	Turn on the UUT. Recall factory defaults with *RST. Set ALC:DET RMS to rms and then program output voltage to VOLT 120, FREQ 60 SHAPE:SIN, CURR 3.00 for 6811A/B – CURR 5.00 for the 6812A/B, 6813A/B, 6841A, 6842A	CC annunciator on, output current near 3 amps for 6811A/B – near 5 amps for the 6812A/B, 6813A/B, 6841A, 6842A
3	Record DVM reading and calculate rms current	Readings are within specified current high range limits.
4	Program CURR:RANGE LOW	CC annunciator on, output current near 5.0 amps
5	Record DVM reading and calculate rms current	Readings are within specified current low range limits.

Table 2-6. Harmonic Distortion Test

Step	Action	Normal Result
This test measures the total harmonic distortion of the output sinewave at full power		
1	Turn off the UUT. Connect load resistor and DMM as shown in Test Setup Figure 2-1 with S1 closed.	
2	Turn on the UUT. Program output voltage to VOLT 300, FREQ 60, SHAPE:SIN, CURR MAX	CV annunciator on, Output current at 1.2 amps for 6811A/B 2.5 amps for 6812A/B, 6841A 5.8 amps for 6813A/B, 6842A
3	Record the total harmonic distortion reading from the audio analyzer and front panel display of UUT.	Readings are less than maximum specified limits.

Table 2-7. Frequency Accuracy Test

Step	Action	Normal Result
This test verifies the frequency programming and measurement accuracy of the output voltage waveform.		
1	Turn off the UUT. Connect Frequency Counter as shown in Test Setup Figure 2-1. If ratio transformer is not used connect Frequency Counter directly to output terminals with S1 open.	
2	Turn on the UUT. Program output voltage to VOLT 100, FREQ 400, SHAPE:SIN, CURR MAX	CV annunciator on.
3	Record the output frequency reading from counter and front panel display of UUT.	Readings are within specified limits @ 400Hz.

Table 2-8. DC Voltage Programming and Readback Accuracy

Step	Action	Normal Result
This test verifies the DC voltage programming and front panel readback functions are within specifications.		
1	Turn off the UUT. Connect DVM directly to the output terminals. DVM negative lead is connected to COM output terminal. Disconnect the 30:1 transformer. Open S1.	
2	Turn on UUT. Program output voltage to VOLT 0, OUTP:COUP DC, OFFSET 425	Output voltage at +425 Vdc, output current near zero.
3	Record dc voltage at DVM and readback from front panel display.	Readings within specified dc voltage programming and readback limits.
4	Program output voltage OFFSET -425	Output voltage at -425 Vdc, output current near zero.
5	Record dc voltage at DVM and readback from front panel display.	Readings within specified DC voltage programming and readback limits.

2 - Performance Tests

Table 2-9. Performance Test Record - HP 6811A/B

Model	Report No:	Date:		
Test Description	Minimum Specification	Results	Maximum Specification	Meas. Uncert.
Voltage Programming & Readback Accuracy				
300Vrms @ 45Hz	299.250	_____ V	300.750	140mV
Front Panel Display	Vrms -190mV	_____ V	Vrms +190mV	(1.2mV)
300Vrms @ 400Hz	298.200	_____ V	301.800	140mV
Front Panel Display	Vrms -400mV	_____ V	Vrms +400mV	(1.2mV)
300Vrms @ 1KHz	296.700	_____ V	303.300	140mV
Front Panel Display	Vrms -700mV	_____ V	Vrms +700mV	(1.2mV)
CV Load Effect	Vout - 1.5V	_____ V	Vout + 1.5V	
CV Line Effect	Vout - 0.3V	_____ V	Vout + 0.3V	
rms Current Readback				
Front Panel Display High Range	Io-0.0175A	_____ A	Io+0.0175A	1mA
Front Panel Display Low Range	Io-0.0045A	_____ A	Io+0.0045A	1mA
Total Harmonic Distortion				
Audio Analyzer	0	_____ %	1%	
Front Panel Display	0	_____ %	1%	
Frequency Programming & Readback Accuracy				
Program 400 Hz	399.960 Hz	_____ Hz	400.040 Hz	0.005Hz
Front Panel Display	Fo - 0.040 Hz	_____ Hz	Fo + 0.040 Hz	
DC Voltage Programming & Readback Accuracy				
+425 VDC Output	424.075 Vdc	_____ Vdc	425.925 Vdc	4.4mV
Front Panel Display	Vo-0.277 Vdc	_____ Vdc	Vo+0.277Vdc	
-425 VDC Output	-424.075 Vdc	_____ Vdc	425.925 Vdc	4.4mV
Front panel Display	Vo-0.277 Vdc	_____ Vdc	Vo+0.277 Vdc	

Note: 1. Measurement uncertainties are only valid when using test equipment listed in Table 2-1.

2. Voltage Programming and Readback measurement uncertainties are for a 3458A DMM in the 1000 volt range.

3. Measurement uncertainties in parenthesis are only if a 30:1 ratio transformer is used with the 3458A DMM.

Table 2-10. Performance Test Record - HP 6812A/B, 6841A

Model	Report No:	Date:		
Test Description	Minimum Specification	Results	Maximum Specification	Meas. Uncert.
Voltage Programming & Readback Accuracy				
300Vrms @ 45Hz	299.250	_____ V	300.750	140mV
Front Panel Display	Vrms -190mV	_____ V	Vrms +190mV	(1.2mV)
300Vrms @ 400Hz	298.200	_____ V	301.800	140mV
Front Panel Display	Vrms -400mV	_____ V	Vrms +400mV	(1.2mV)
300Vrms @ 1KHz	296.700	_____ V	303.300	140mV
Front Panel Display	Vrms -700mV	_____ V	Vrms +700mV	(1.2mV)
CV Load Effect	Vout - 1.5V	_____ V	Vout + 1.5V	
CV Line Effect	Vout - 0.3V	_____ V	Vout + 0.3V	
rms Current Readback				
Front Panel Display High Range	Io-0.0175A	_____ A	Io+0.0175A	1mA
Front Panel Display Low Range	Io-0.0045A	_____ A	Io+0.0045A	1mA
Total Harmonic Distortion				
Audio Analyzer	0	_____ %	1%	
Front Panel Display	0	_____ %	1%	
Frequency Programming & Readback Accuracy				
Program 400 Hz	399.960 Hz	_____ Hz	400.040 Hz	0.005Hz
Front Panel Display	Fo - 0.040 Hz	_____ Hz	Fo + 0.040 Hz	
DC Voltage Programming & Readback Accuracy				
+425 VDC Output	424.075 Vdc	_____ Vdc	425.925 Vdc	4.4mV
Front Panel Display	Vo-0.277 Vdc	_____ Vdc	Vo+0.277Vdc	
-425 VDC Output	-424.075 Vdc	_____ Vdc	425.925 Vdc	4.4mV
Front panel Display	Vo-0.277 Vdc	_____ Vdc	Vo+0.277 Vdc	

Note: 1. Measurement uncertainties are only valid when using test equipment listed in Table 2-1.

2. Voltage Programming and Readback measurement uncertainties are for a 3458A DMM in the 1000 volt range.

3. Measurement uncertainties in parenthesis are only if a 30:1 ratio transformer is used with the 3458A DMM.

2 - Performance Tests

Table 2-11. Performance Test Record - HP 6813A/B, 6842A

Model	Report No:	Date:		
Test Description	Minimum Specification	Results	Maximum Specification	Meas. Uncert.
Voltage Programming & Readback Accuracy				
300Vrms @ 45Hz	299.250	_____ V	300.750	140mV
Front Panel Display	Vrms -190mV	_____ V	Vrms +190mV	(1.2mV)
300Vrms @ 400Hz	298.200	_____ V	301.800	140mV
Front Panel Display	Vrms -400mV	_____ V	Vrms +400mV	(1.2mV)
300Vrms @ 1KHz	296.700	_____ V	303.300	140mV
Front Panel Display	Vrms -700mV	_____ V	Vrms +700mV	(1.2mV)
CV Load Effect	Vout - 1.5V	_____ V	Vout + 1.5V	
CV Line Effect	Vout - 0.3V	_____ V	Vout + 0.3V	
rms Current Readback				
Front Panel Display High Range	Io-0.0175A	_____ A	Io+0.0175A	1mA
Front Panel Display Low Range	Io-0.0045A	_____ A	Io+0.0045A	1mA
Total Harmonic Distortion				
Audio Analyzer	0	_____ %	1%	
Front Panel Display	0	_____ %	1%	
Frequency Programming & Readback Accuracy				
Program 400 Hz	399.960 Hz	_____ Hz	400.040 Hz	0.005Hz
Front Panel Display	Fo - 0.040 Hz	_____ Hz	Fo + 0.040 Hz	
DC Voltage Programming & Readback Accuracy				
+425 VDC Output	422.575 Vdc	_____ Vdc	427.425 Vdc	4.4mV
Front Panel Display	Vo-0.277 Vdc	_____ Vdc	Vo+0.277Vdc	
-425 VDC Output	-422.575 Vdc	_____ Vdc	427.425 Vdc	4.4mV
Front panel Display	Vo-0.277 Vdc	_____ Vdc	Vo+0.277 Vdc	

Note: 1. Measurement uncertainties are only valid when using test equipment listed in Table 2-1.

2. Voltage Programming and Readback measurement uncertainties are for a 3458A DMM in the 1000 volt range.

3. Measurement uncertainties in parenthesis are only if a 30:1 ratio transformer is used with the 3458A DMM.

Principles of Operation

Introduction

Figure 3-1 at the end of this chapter is a block diagram showing the major circuits within the AC Power Source /Analyzer and Harmonic / Flicker Test System. These units consist of the following modules.

- A1 AC Input assembly
- A2 HP-IB Assembly
- A3 AC FET Assembly
- A4 AC Input Assembly
- A5 DC Rail Assembly
- A6 Bias Assembly
- A7 Inverter Assembly
- A8 DSP Assembly
- A9 Output Filter Assembly
- A10 Control Assembly
- A11 Trigger Assembly

General Description

The 6811A/B, 6812A/B, and 6813A/B are 375VA, 750VA and 1750VA AC Source/Analyzers whereas the 6841A and 6842A are 750VA and 1750VA power sources are used as Harmonic / Flicker Test Systems. The 6811A/B, 6812A/B and 6841A can operate from 120, 220 or 240 volt AC input main while the 6813A/B and 6842A only operate from 220/240 volt AC input mains. All deliver regulated AC voltage and/or current from 45 to 1000 hertz. They can operate below 45 hertz to DC at derated output power. (see Users Guide for operation below 45 hertz). They can generate sine, square, clipped sine or arbitrary waveforms. The output waveform can be controlled from the front panel keypad or computer via HP-IB or RS-232. The output characteristics or measurements (voltage, current, frequency, power factor, etc.) can be readback via the front panel, HP-IB or RS-232.

A1 Front Panel Assembly

The A1 Intelligent Front Panel assembly contains a circuit board, a vacuum florescent display assembly, keypad and rotary pulse generators (RPG). The circuit board contains digital logic circuits including a CPU, ROM and RAM. The front panel CPU decodes operator keystrokes and transmits the information to the A8 DSP assembly. The front panel receives information from the A8 DSP assembly to update the display. The front panel assembly is a surface mount (SMT) assembly and is not component level repairable. The A1 front panel assembly is common to all models.

3 - Principles of Operation

A2 HP-IB / RS-232 Interface Assembly

The A2 HP-IB / RS-232 interface assembly contains the CPU and GPIB interface controller for communicating with a HP-IB (GPIB) controller. The A2 interface assembly also contains the logic for communicating with a computer via RS-232. The interface type, HP-IB or RS-232, is determined by the operator using front panel keystrokes. When using the RS-232 interface the operator can select the baud rate and parity using the front panel keypad. The HP-IB / RS-232 interface assembly is an SMT assembly and is not component level repairable. The A2 assembly is common to all models.

A3 FET Assembly

The 6813A/B and 6842A A3 FET assembly contains 8 power FETs and 2 bridge driver ICs. The power FETS and power transformer form an H-Bridge converter. The A3 FET H-Bridge converts the 320 volt DC rail from the AC Input assembly to 500 volts DC on the A9 Output assembly via the A5 DC Rail assembly. The A3 assembly power FETs switching frequency is synchronized with the switching frequency of the A7 Inverter assembly. The A3 FET switching frequency is approximately 42 KHz, 1/2 that of the A7 Inverter assembly.

The 6811A/B, 6812A/B and 6842A ACFET assemblies, having lower output power ratings than the 6813A/B and 6842A/B , use only 4 power FETs in the H-Bridge. These assemblies are component level repairable except for a FET failure. Power FETs replacement requires that all FETs in the H-Bridge have the same manufacture and same date code, therefore when a FET replacement is required it may be more practical to replace the ACFET assembly. The 6811A/B, 6812A/B and 6841A use one common assembly, the 6813A and 6842A use a different unique assembly. .

A4 AC Input Assembly

The AC input mains voltage is connected on the rear panel via J1049 to the A4 AC Input board. The AC input board converts the AC mains to a nominal 320 volt DC rail for use by the AC FET assembly. Relays K1040 and K1041 prevent the DC rail from energizing until the front panel on/off switch closed. Resistors R1040, R1041, R1045 and R1046 limit turn-on surge current to the input filter capacitors C1060 thru C1067. Relay K1040 bypasses the current limit resistors when energized. Relay K1040 is controlled by FET Q1040 who is driven by the input_rly_iso signal derived from the DSP assembly. Wire jumper J1047 connects the full wave bridge rectifier D1060 and input capacitors C1060 thru C1067 as either a voltage doubler for 120 volt mains or full wave bridge for 220/240 volt mains. Fuse F1020 is the main AC line fuse and F1080 protects the 320 volt DC rail to the AC FET assembly. The A4 assembly is component level repairable and there are 3 unique assemblies. One for the 6811A/B, another for the 6812A/B and 6841A and another for the 6813A/B and 6842A.

A5 DC Rail Assembly

The A5 DC Rail assembly contains U447 the CV error amplifier, U491 PWM driver, U462 PWM comparator and U475 ramp generator to control the FET H-bridge on the A3 ACFET assembly. The chassis mounted power transformer connects the 42 KHz AC from the A3 ACFET assembly to input rectifiers D400 thru D407 on the A5 DC Rail board.

Chassis mounted rail filter 5080-2329 and capacitors C500 to C503 and C508 to C509 located on the A9 Output Filter board convert the 42 KHz AC to a 503 volt DC rail for use by the A7 Inverter assembly. It also contains U423 bias voltage detector and high/low 503 volt rail voltage detection circuit. There is a red LED on the right side of the A5 DC Rail assembly to warn when high voltages are present, this LED can be seen from the right side of the AC Source without removing any covers. This assembly is component level repairable but extreme caution must be used when troubleshooting as 1100 volts peak / 503VDC is present. The A5 DC Rail assembly is common to all models.

A6 Bias Assembly

The A6 Bias assembly receives the AC input mains voltage via connector J1035 from the A4AC Input assembly. The bias transformer primaries for models 6811A/B, 6812A/B, or 6841A can be configured for either 100, 120, 200 or 230 volt nominal input and models 6813A/B and 6842A can only be configured for 200 or 230 volt nominal inputs. The input voltage range is configured by moving jumpers on J353. A J353 jumper configuration diagram is located on the bias assembly next to J353. Regulator U300 supplies +15 volts to the AC input relays and bias to the ACFET assembly. Regulators U311 and U3121 supply +5 volts to the HPIB and front panel assemblies. Opto-coupler U362 transmits the input_rly_iso signal to relay K1040 on the AC input assembly. J337 supplies +5 and +/- 15 volts to the control assembly via the Output Filter assembly and 48 volts AC via E336 to the DC rail assembly. The A6 assembly is a component level repairable assembly. There is one unique assembly for the 6811A/B, 6812A/B and 6841A and another unique assembly for the 6813A/B and 6842A.

A7 Inverter Assembly

The A7 Inverter (output amplifier) assembly is a switching H-bridge FET assembly operating at approximately 83 KHz. It receives its switching logic from the A10 control assembly. The A7 Inverter assembly can provide a sine, square, clipped sine, arbitrary waveform or DC level to the A9 Output Filter assembly. The HP 6813A/B and 6842A uses twice as many power FETs as the HP 6811A/B, 6812A/B and 6841A assembly. *Slow start* procedures, disconnecting the 503 volt DC rail, should be used when troubleshooting the Inverter assembly. See Inverter troubleshooting for more complete information on *slow start* procedures. The A7 Inverter assemblies are component level repairable except for a FET failure. Power FETs replacement requires that all FETs in the H-Bridge have the same manufacture and same date code, therefore when a FET replacement is required it may be more practical to replace the A7 Inverter assembly. There is one unique A7 Inverter assembly for HP models 6811A/B, 6812A/B and 6841A and another unique assembly for models 6813A/B and 6842A. .

A8 Digital Signal Processing (DSP) Assembly

The A8 DSP assembly contains the CPU, ROMs, Digital-to Analog (DACs) circuits that control the output voltage and output current settings. It contains Analog-to-Digital (ADCs) circuits to readback actual output voltage and current. It contains all logic circuits for generating arbitrary waveforms, frequency changes and transient or pulse level changes. At power on the A8 DSP assembly performs a self test and reports any failures via the front panel display. The A8 assembly is an SMT assembly and is not component level repairable except for the ROMs which are installed in sockets and are replaceable for ROM upgrades. There is one unique assembly for models 6811A/B, 6812A/B, and 6813A/B and another unique assembly for models 6841A and 6842A.

A9 Output / Filter Assembly

The A9 Output filter assembly contains U500 the remote sense amplifier and K501 remote sense relay. The rms and peak current sense resistors, overvoltage divider and output disconnect relays K502 and K503 (older manufactured units use one output disconnect relay K500). The A9 Output assembly contains 2 notch filters to reduce the inverter switching frequency noise in the output. It provides a communication path between the A10 Control assembly, A5 DC rail assembly and A6 Bias assembly. The A9 assembly is component level repairable. There is one unique assembly for model 6811A/B and another unique assembly for models 6812A/B, 6813A/B, 6841A and 6842A.

3 - Principles of Operation

A10 Control Assembly

The A10 Control assembly contains the PWM comparator and ramp generator for controlling the A7 Inverter assembly power FETs. It contains the voltage and current rms/dc converter circuits, voltage and current readback amplifiers and all other analog circuits required to interface the output voltage , output current and frequency programming and measurement capabilities with the A8 DSP assembly. The A10 assembly is an SMT assembly and is not component lever repairable. There are three unique A10 Control assemblies, one for model 6811A/B, one for models 6812A/B, and 6841A and one for models 6813A/B, and 6842A.

A11 Trigger (BNC) Assembly

The A11 Trigger or BNC assembly provides the communication and isolation path for trigger out (U157) and trigger in signals (U156). The A11 assembly provides the isolation (optical couplers) between the the A2 HP-IB interface assembly (U153 & U154) and A8 DSP assembly (J115). The A11 assembly is an SMT assembly and is common to all models.

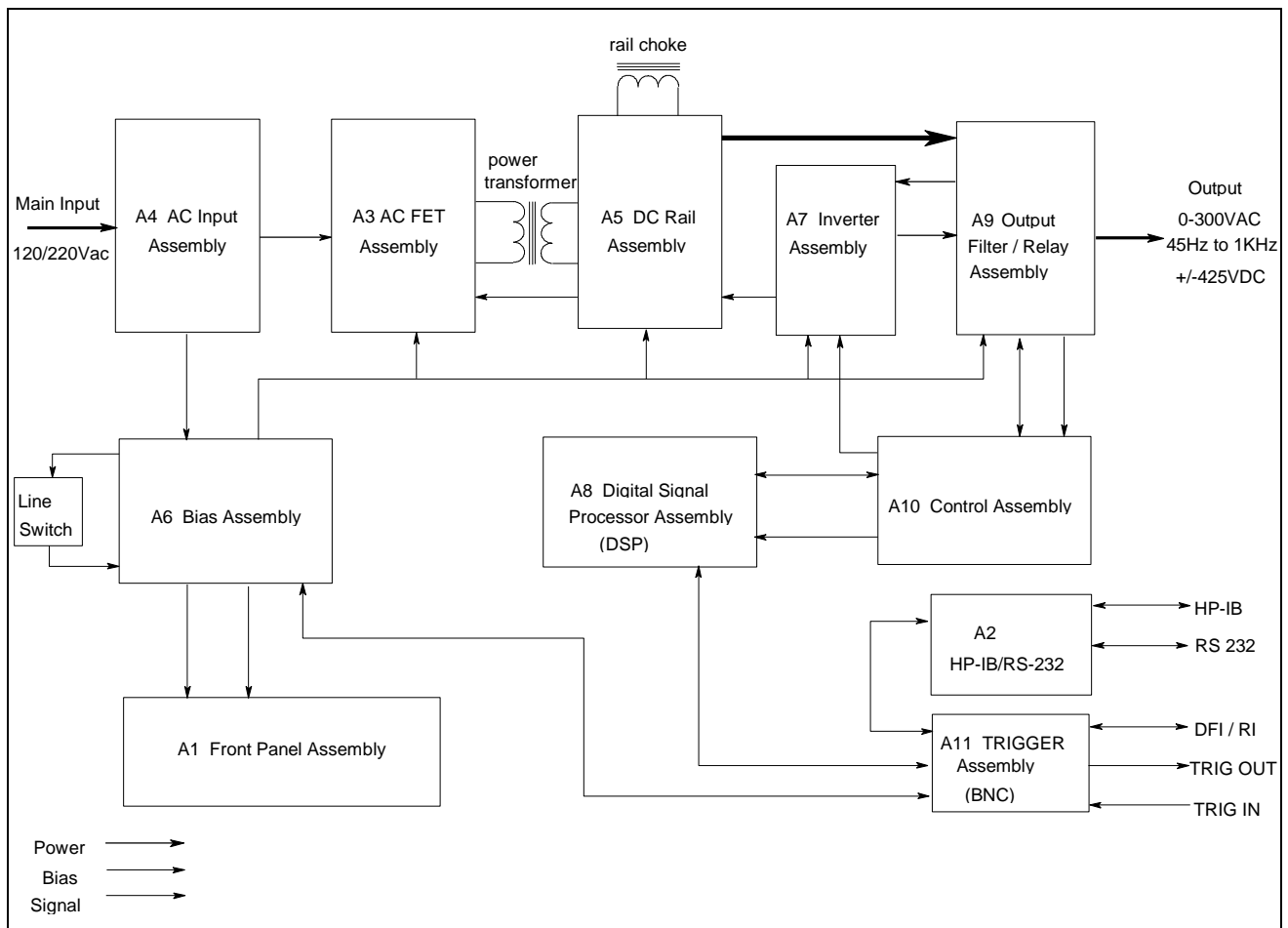

Figure 3-1. AC Power Source/Analyzer Block Diagram

Troubleshooting

Introduction

WARNING: ***SHOCK HAZARD.*** The troubleshooting procedures in this chapter are performed with power applied and protective covers removed. These procedures should be performed only by service trained personnel who are aware of the hazards (e.g., fire and electrical shock).

CAUTION: This instrument uses components which can either be damaged or suffer serious performance degradation as a result of ESD (electrostatic discharge). Observe the standard antistatic precautions to avoid damage to the components. An ESD summary is given in Chapter 1.

This chapter provides troubleshooting and repair information for the AC Power Source. Before beginning troubleshooting procedures make certain the problem is in the AC Power Source and not with an associated circuit, the HP-IB controller or AC input lines. Without removing the covers you can use the verification tests in chapter 2 to determine if the AC Power Source is operating normally.

Test Equipment Required

Table 4-1 lists the equipment required to perform the troubleshooting procedures given in this chapter.

Table 4-1. Test Equipment Requirements for Troubleshooting

Equipment	Characteristics	Recommended Model
HP-IB Controller	Communicate with AC Source via HP-IB or RS232	HP Series 200/300 controller or Equivalent.
Digital Voltmeter	Check voltages / resistances	HP 3458A or equivalent
Function Generator	Generate waveforms	HP 3312A or equivalent
Oscilloscope	Observe waveforms	HP54504A or equivalent
Current Shunt	Check output current	0.01 ohm 10 watt
Logic Probe	Check data lines	HP545A or equivalent

Troubleshooting Hints

Service kit 5063-2330 contains 2 pc board holders to hold the A5 DC Rail board in a vertical position for troubleshooting, and a pc board extender that raises the A8 DSP and A10 Control boards above the chassis for troubleshooting.

Extender board part number 5063-2331
 PCB holder part number 5020-8458
 Cable part number 5080-2381

Locate and observe the 2 red LEDs which indicate when high voltage is present on the A4 AC input board, A5 DC rail board, and A9 output board. Wait for the LEDs to extinguish before removing or installing assemblies.

If both CV and CC annunciators are on, the peak current limit may be set to low.

Power-on Self-test Failures

The power-on self-test sequence tests most of the digital and DAC circuits. If the supply fails self-test, the display "ERR" annunciator will come on. You can then query the unit to find out what the error(s) are. When an error is detected, the output is not disabled so you can still attempt to program the supply to help troubleshoot the unit. Table 4-2 lists the self-test errors and gives a possible remedy for each error. Table 4-3 lists the run-time errors that can occur at any time while the unit is running.

NOTE: A partial self test is performed when the *TST? query is executed. Those tests that interfere with normal interface operation or cause the output to change are not performed by *TST?. The return value of *TST? will be zero if all tests pass, or the error code of the first test that failed. The power supply will continue normal operation if *TST? returns a non-zero value.

Table 4-2. Self-Test Errors

Error #	Description	Possible Remedy
0	No error	-
1	Non-volatile RAM RD0 section checksum failed	A
2	Non-volatile RAM CONFIG section checksum failed	A
3	Non-volatile RAM CAL section checksum failed	A
4	Non-volatile RAM WAVEFORM section checksum failed	A
5	Non-volatile RAM STATE section checksum failed	A
6	Non-volatile RAM LIST section checksum failed	A
7	Non-volatile RAM RST section checksum failed	A
10	RAM selftest	B
11 - 31	DAC selftest error, expected <n>, read <reading> Errors 11, 12, 13, 14, 15 apply to DAC12 1A and 1B Errors 16, 17, 18 apply to DAC12 2A Errors 19, 20, 21 apply to DAC12 2B Errors 22, 23 apply to DAC12 4A Errors 24, 25 apply to DAC12 4B Errors 26, 27, 28 apply to DAC12 3A and 3B Errors 29, 30, 31 apply to DAC12 5A and 5B	B
40	Voltage selftest error	C
43	Current selftest error	C
70	Fan voltage failure	D
80	Digital I/O selftest error	D

A Re-initialize unit and re-calibrate. If unit still has RAM error replace A8 DSP board.

B Check A8 DSP and A10 Control assemblies

C *TST? programs 50 volts, expected readback 50+/-1volt 0+/-1amp

D Check fan and/or fan voltage or replace A8 DSP assembly.

Run-Time Errors

Run-time errors do not occur during self-test, but can occur at any time while the unit is running. (see Table 4-3).

Table 4-3. Run-Time Errors

Error #	Description	Possible Remedy
200	Outgrd not responding	E
201	Front panel not responding	F
210	Ingrd receiver framing error	E
211	Ingrd uart overrun status	E
212	Ingrd received bad token	E
213	Ingrd receiver buffer overrun	E
214	Ingrd input buffer overrun	E
215	Outgrd output buffer overrun	E
216	RS-232 receiver framing error	G
217	RS-232 receiver parity error	G
218	RS-232 receiver overrun error	G
219	Ingrd inbuf count sync error	E
220	Front panel uart overrun	F
221	Front panel uart framing	F
222	Front panel uart parity	F
223	Front panel buffer overrun	F
224	Front panel timeout	F
401	CAL switch prevents calibration	H
402	CAL password is incorrect	H
403	CAL not enabled	J
404	Computed readback cal constants are incorrect	J
405	Computed programming cal constants are incorrect	J
406	Incorrect sequence of calibration commands	J
600	Systems in mode:list have different list lengths	K
601	Requested voltage and waveform exceeds peak voltage capability	K
602	Requested voltage and waveform exceeds transformer volt-second rating	K
603	Command only applies to RS-232 interface	K
604	Trigger received before requested number of pre-trigger readings	K
605	Requested RMS current too high for voltage range	K
606	Waveform data not defined	K
607	VOLT, VOLT:SLEW, and FUNC:SHAP modes incompatible	K
608	Measurement overrange	K
609	Output buffer overrun	K
610	Command cannot be given with present SYST:CONF setting	K

- E Communication error between A1 HPIB, A8 DSP and/or A11 trigger assemblies.
- F Communication error between A3 front panel, A8 DSP and /or A11 Trigger assemblies.
- G RS-232 communication or programming error.
- H Check CAL switch positions (see Figure 4-11).
- J See Appendix B in User's Guide for calibration procedure.
- K Programming error (see applicable programming command in Programming Guide).

Overall Troubleshooting Flowchart

Figure 4-1 gives the overall procedures to isolate a fault to a circuit board or particular circuit. See figure 6-1 for the location of the circuit boards.

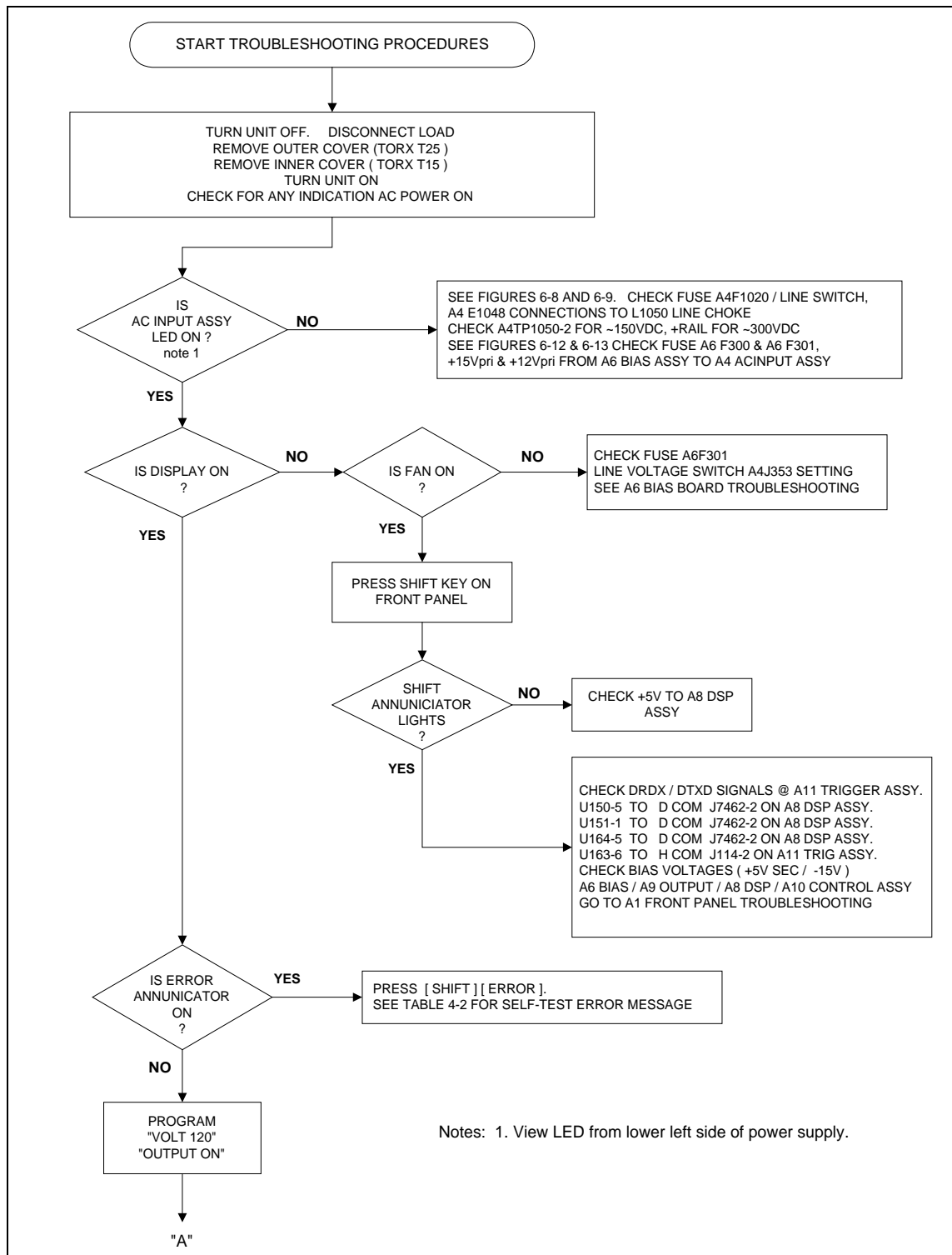

Figure 4-1. Overall Troubleshooting Procedures (sheet 1 of 2)

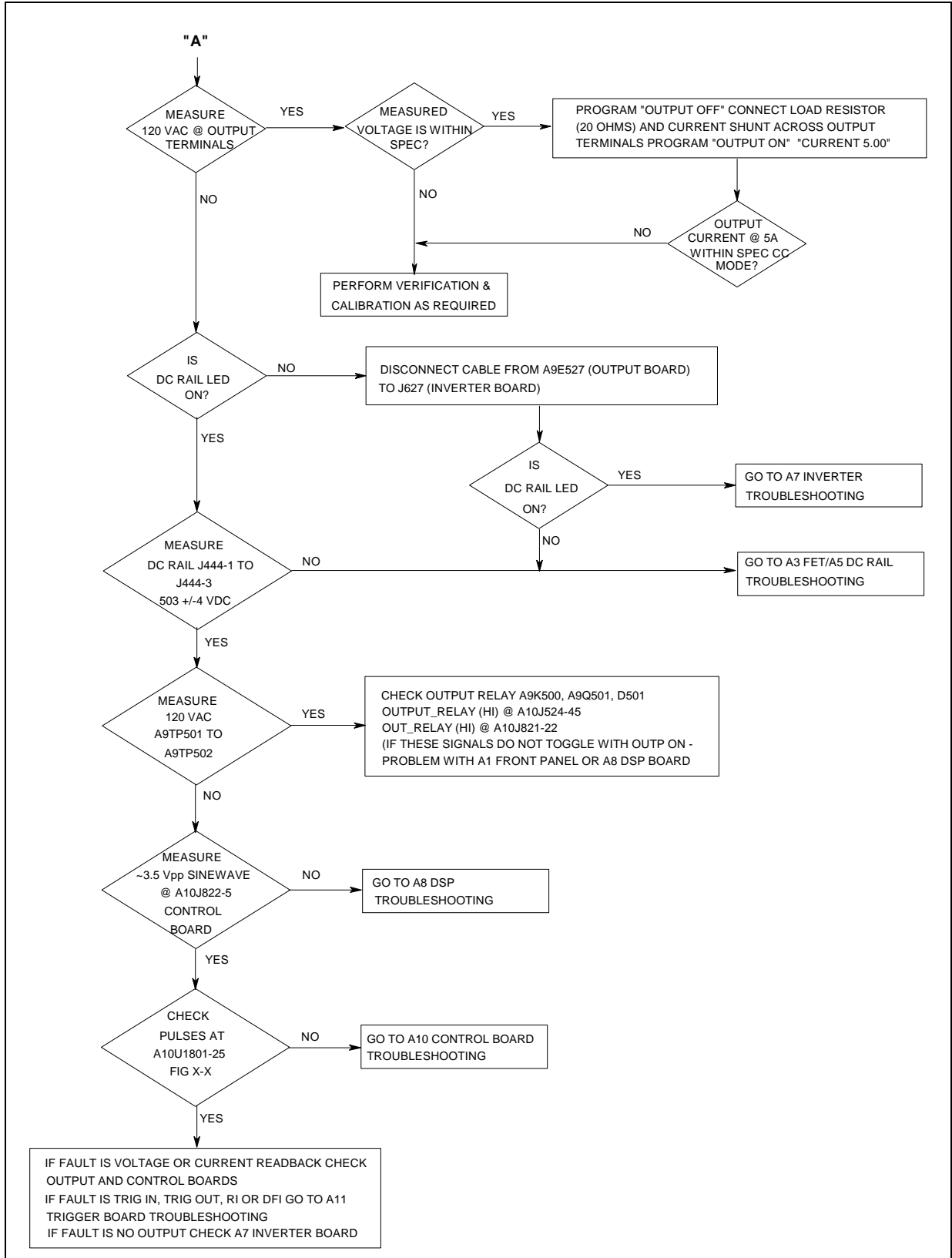

Figure 4-1. Overall Troubleshooting Procedures (sheet 2 of 2)

A1 Front Panel Assembly Troubleshooting

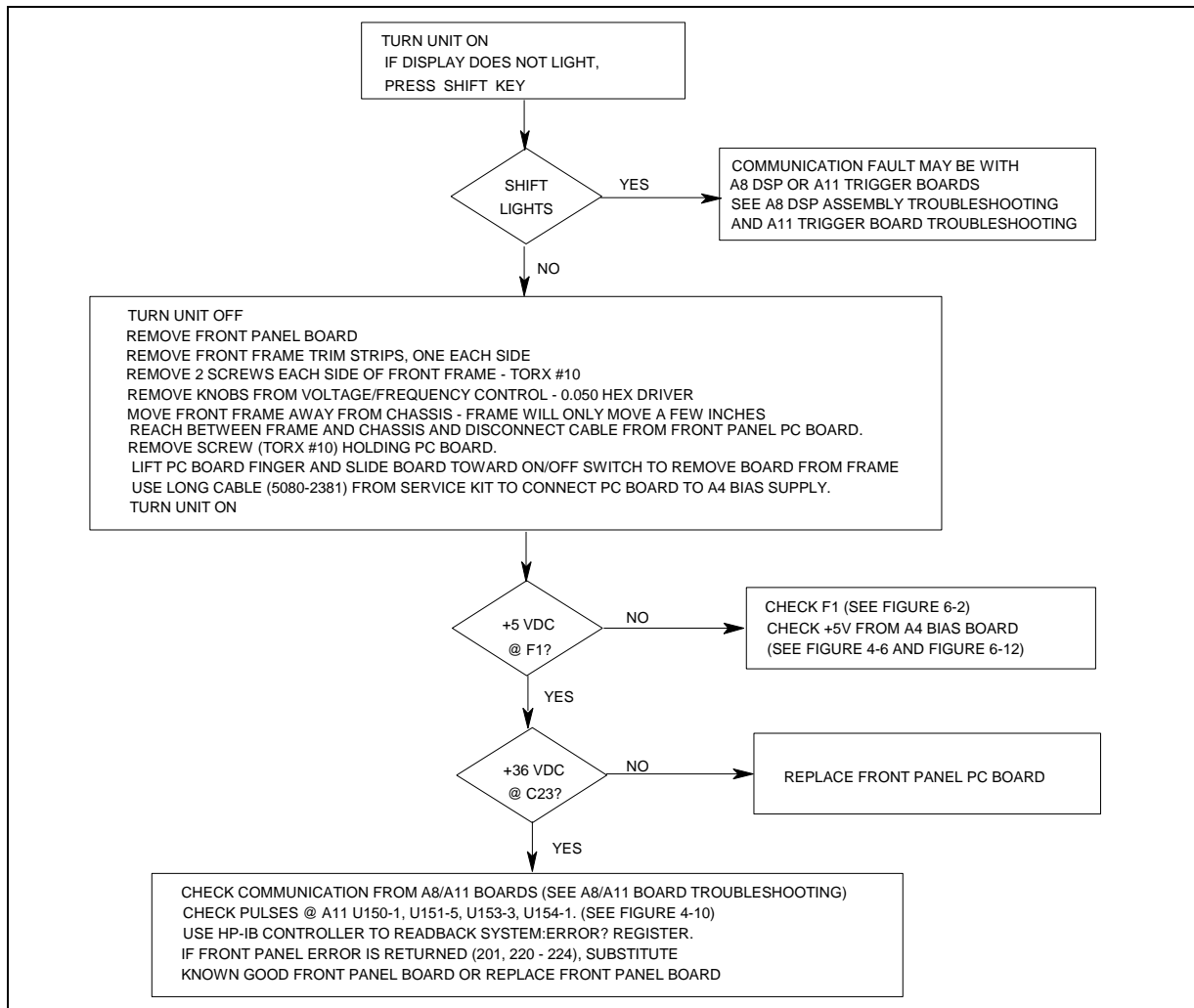

Figure 4-2. Front Panel Assembly Troubleshooting

A2 HP-IB/RS-232 Board Troubleshooting

Table 4-4. HP-IB/RS232 Board Troubleshooting

Step	Procedure	Waveform
1.	Check for +5 Vdc at L100 (see Figure 6-5 for location).	
2.	Check for clock waveform at Y100.	
3.	Connect the unit to an HP-IB or RS232 controller to check the HP-IB/RS232 transceivers. Note that HP-IB and RS232 use separate communication transceivers.	

A3 FET Board Troubleshooting

Because test points on the FET board are not accessible when the board is installed, troubleshooting must be performed with the board removed from the power supply. Troubleshooting procedures are provided with both power removed and power applied. The location of different test points are shown by encircled numbers on the A3 FET Board schematic and component location diagrams.

NOTE: If any power FET (Q201-204, Q211, Q222, Q233, or Q244) is defective, you must replace all eight with a matched set.

Table 4-5. FET Board Troubleshooting

Step	Procedure	Result
With all power removed		
1	Turn the power supply off and remove the A3 FET board with its heatsink assembly attached (see Disassembly Procedures).	see Disassembly Procedures
2	Measure the resistance between the +Rail (E502) and the - Rail (E501) and common (-Rail).	Value should be >20 M Ω
3	Measure the resistance between the gate of each FET (Q201-204, Q211, Q222, Q233, and Q244) and common (-Rail).	Value should be >15 k Ω
4	Measure the resistance across capacitor C201.	Value should be approx. 150 Ω
5	Measure the resistance across the 15 V bias input (E506 to E507).	Value should be approx. 1 k Ω in the forward direction and 490 Ω reversed.
With signal from external waveform generator applied		
6	Short the collectors of Q251 and Q252 by connecting the collector (case) of each transistor to common (E507).	
8	Connect a waveform generator to J200-1 and J200-2.	
9	Set generator to produce a 20kHz, 20Vp-p triangular waveform.	see Figure 4-3A
10	Connect 15 V from an external supply to E506 (positive) and E507 (common). Note: All of the following measurements are taken with respect to E507 common (same as TP 26 on A3 FET Board).	Value should be approx. 1 k Ω in the forward direction and 490 Ω reversed.
11	Check bias voltage at U203-1 (TP 27).	+5V
12	While adjusting the external 15 V supply input, check the bias trip point at U204-1 (TP 28).	Voltage goes from low of 0V to high of 5V at an input of approx. 12V, and from high to low at an input of approx. 13V
13	Set external supply input to + 15V and check drive 1 waveform at U201-10 (TP 29), and drive 2 waveform at U201-12 (TP 30).	See figure 4-3B
14	Check that pulses are present at U201-1(TP 31), U201-7 (TP 32), U202-1 (TP 33), and U202-7 (TP 34)	See figure 4-3C
15	Pulses should be present on both sides of inductors L201-204 and L213-216 as follows: Check the pulses on the driver transistor side (Q251-Q254) of each inductor. Check the pulses on the FET regulator side (Q201-Q204, Q211, Q222, Q233, and Q244) of each inductor. If the waveforms do not have the fast step as shown in Figure 4-3, then the associated FET gate input has an open circuit.	See Figure 4-3D See Figure 4-3E
16	Measure the VREF voltage at U204-4 (TP 35).	approx. 1.7 V
17	Check the peak current limit by connecting a 68 Ω resistor from +5 V (U201-9) to U204-5.	All pulses turned off

4 - Troubleshooting

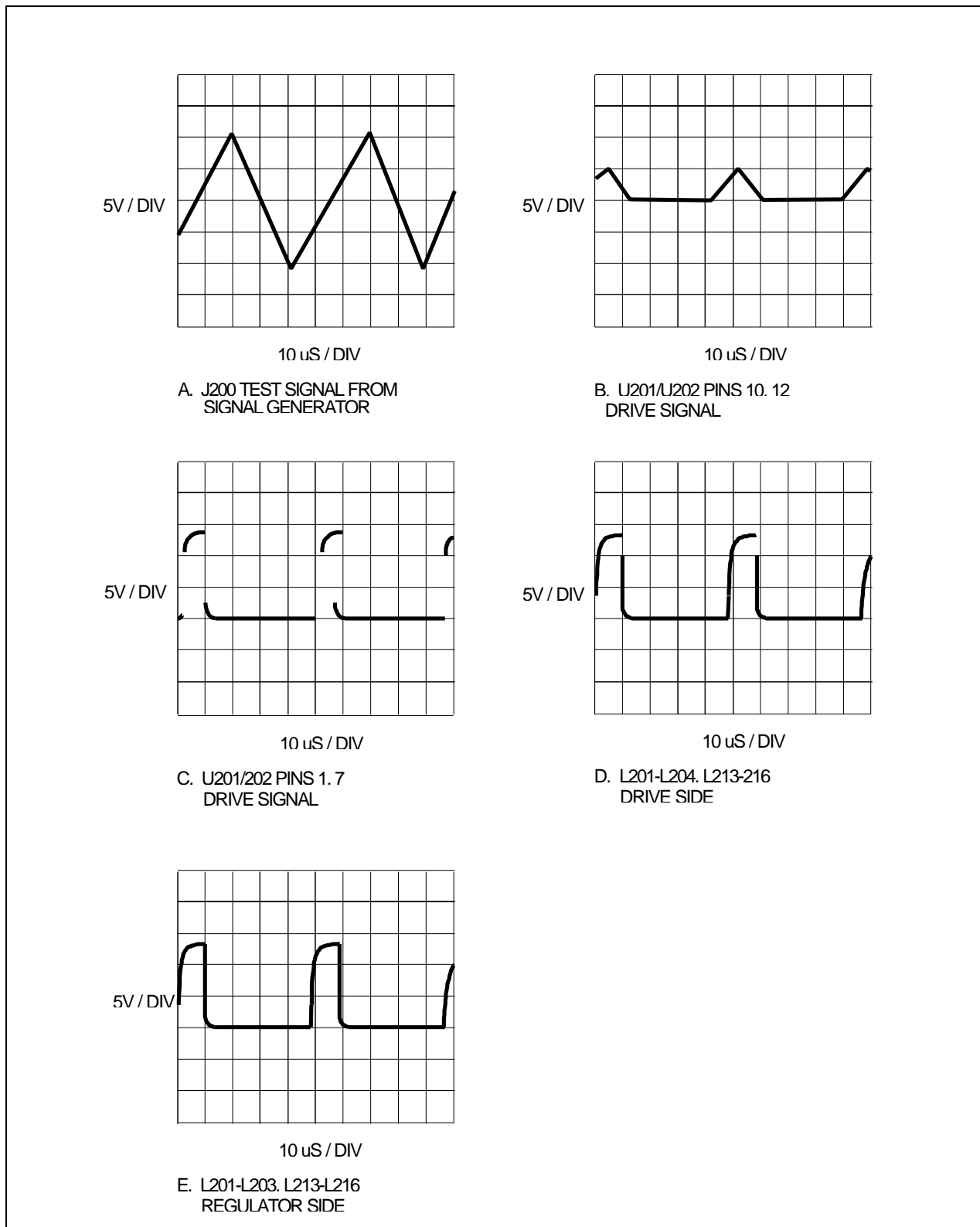

Figure 4-3. FET Assembly Test Waveforms

A5 DC Rail Assembly Troubleshooting

CAUTION: This board contains hazardous voltages during some troubleshooting procedures. Use extreme caution.

Before troubleshooting the A5 DC Rail board, refer to the previous procedure and determine that the A3 AC FET Assembly is good. The 503 Vdc rail (+/-4Vdc) is generated from the 300Vac input board rail, the A3 FET board, and the power transformer. The A5 DC Rail board contains the PWM and CV error amplifiers for controlling the FET switches. Troubleshooting the bias, PWM, and CU error amplifiers must be done with the 300Vdc rail disconnected from the A3 FET assembly

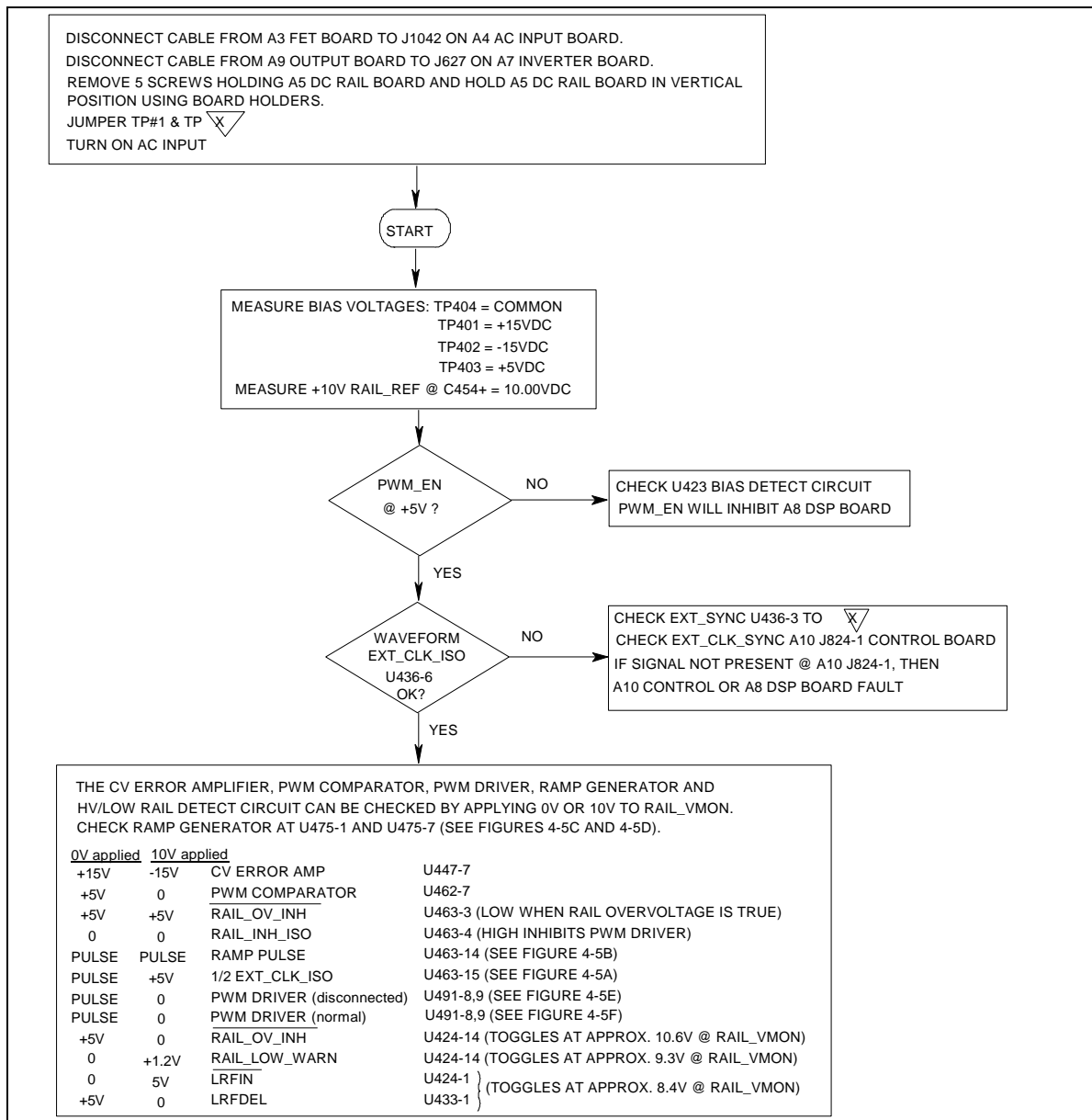

Figure 4-4. DC Rail Assembly Troubleshooting

4 - Troubleshooting

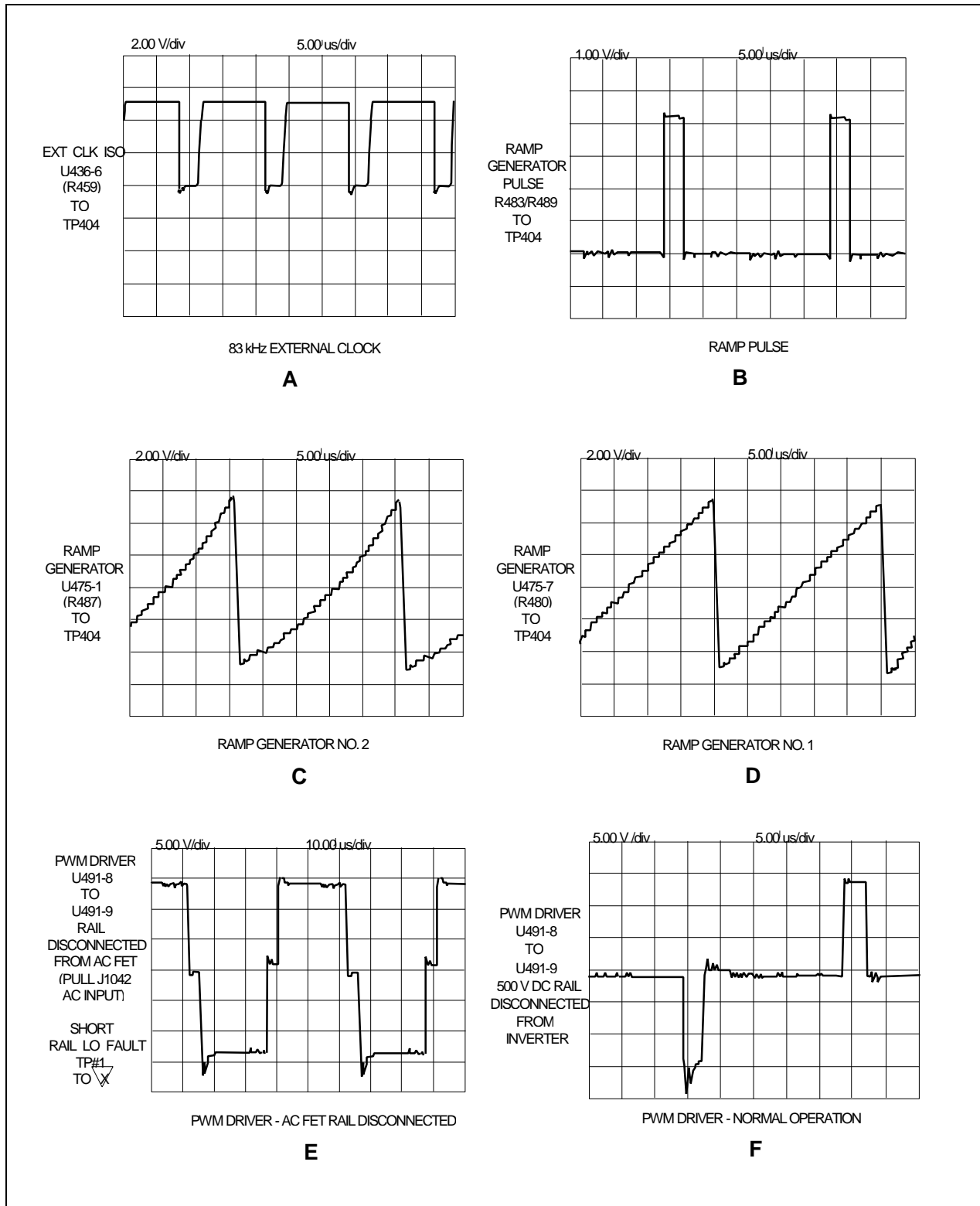

Figure 4-5. DC Rail Assembly - Test Waveforms

A6 Bias Assembly Troubleshooting

Checking the A6 Bias Assembly consists of checking the bias voltages and the fan speed control circuit.

NOTE: You can determine if any of the bias voltage regulators are operating in current limit mode by disconnecting the cable going to the circuit where the bias is used. If the bias voltage returns to normal with the cable disconnected, most likely the bias circuit is OK.

Table 4-6. Bias Assembly Troubleshooting

Step	Procedure	Result																																				
1	Check F301	If open, replace fuse. If fuse blows again, troubleshoot the bias circuits.																																				
2	<p>Check the the bias voltages at the following locations. Measure at the following points:</p> <table border="0"> <tr> <td><u>Test point</u></td> <td>and</td> <td><u>Common point</u></td> </tr> <tr> <td>C314+</td> <td></td> <td>C302- (P)</td> </tr> <tr> <td>C304+</td> <td></td> <td>C302- (P)</td> </tr> <tr> <td>C313+</td> <td></td> <td>C317- (H)</td> </tr> <tr> <td>U312 tab</td> <td></td> <td>C317- (H)</td> </tr> <tr> <td>U311 tab</td> <td></td> <td>C317- (H)</td> </tr> <tr> <td>U322 tab</td> <td></td> <td>C329+ (Y)</td> </tr> <tr> <td>C331 tab</td> <td></td> <td>C329+ (Y)</td> </tr> <tr> <td>E346-2</td> <td></td> <td>D322 (F)</td> </tr> <tr> <td>E346-1</td> <td></td> <td>D322 (F)</td> </tr> <tr> <td>E336-2</td> <td></td> <td>E336-3</td> </tr> <tr> <td>E336-1</td> <td></td> <td>E336-3</td> </tr> </table>	<u>Test point</u>	and	<u>Common point</u>	C314+		C302- (P)	C304+		C302- (P)	C313+		C317- (H)	U312 tab		C317- (H)	U311 tab		C317- (H)	U322 tab		C329+ (Y)	C331 tab		C329+ (Y)	E346-2		D322 (F)	E346-1		D322 (F)	E336-2		E336-3	E336-1		E336-3	<p>+12 Vdc (+12V PRI to A4 Input board) +15 Vdc (+15V PRI to A3 FET board) +12 to 15 Vdc (+5V UNREG to U311, U312) +5 Vdc (+5VDC to A1 Front Panel) +5 Vdc (+5V DC to A2 HP-IB board) +15 Vdc (+15VSEC to A8 DSP, A9 Output, A10 Control boards) -15 Vdc (-15VSEC to A8 DSP, A9 Output, A10 Control boards) +25 to 30 Vdc (+25 V UNREG to A7 Inverter, A8 DSP boards) +5 V (+5 V SEC to A7 Inverter, A8 DSP boards) ~22 Vac (~22Vac to dc rail bias regulator) ~44 Vac (~44Vac to dc rail bias regulator)</p>
<u>Test point</u>	and	<u>Common point</u>																																				
C314+		C302- (P)																																				
C304+		C302- (P)																																				
C313+		C317- (H)																																				
U312 tab		C317- (H)																																				
U311 tab		C317- (H)																																				
U322 tab		C329+ (Y)																																				
C331 tab		C329+ (Y)																																				
E346-2		D322 (F)																																				
E346-1		D322 (F)																																				
E336-2		E336-3																																				
E336-1		E336-3																																				
3	<p>Check the fan speed supply by measuring the voltage at:</p> <table border="0"> <tr> <td><u>Test point</u></td> <td>and</td> <td><u>Common point</u></td> </tr> <tr> <td>C361+</td> <td></td> <td>D322 (F)</td> </tr> </table>	<u>Test point</u>	and	<u>Common point</u>	C361+		D322 (F)	4.7 Vdc (in AUTO mode)																														
<u>Test point</u>	and	<u>Common point</u>																																				
C361+		D322 (F)																																				
3	<p>Change the fan speed and check for the correct voltage as follows: Press 0 and 9 simultaneously. Press p twice, ã once, and ENTER Press 0 and 9 simultaneously. Press p once. Enter a fan speed, then ENTER</p>	<p>EE INIT <model> FAN:MODE MAN EE INIT <model> FAN:SPEED <n> 10 = 5.7 Vdc 50 = 9.6 Vdc 100 = 14.6 Vdc</p>																																				
4	<p>After the fan speed test, enter the following command: SHIFT OUTPUT q ENTER This restores the fan speed to automatic mode.</p>	*RST																																				

4 - Troubleshooting

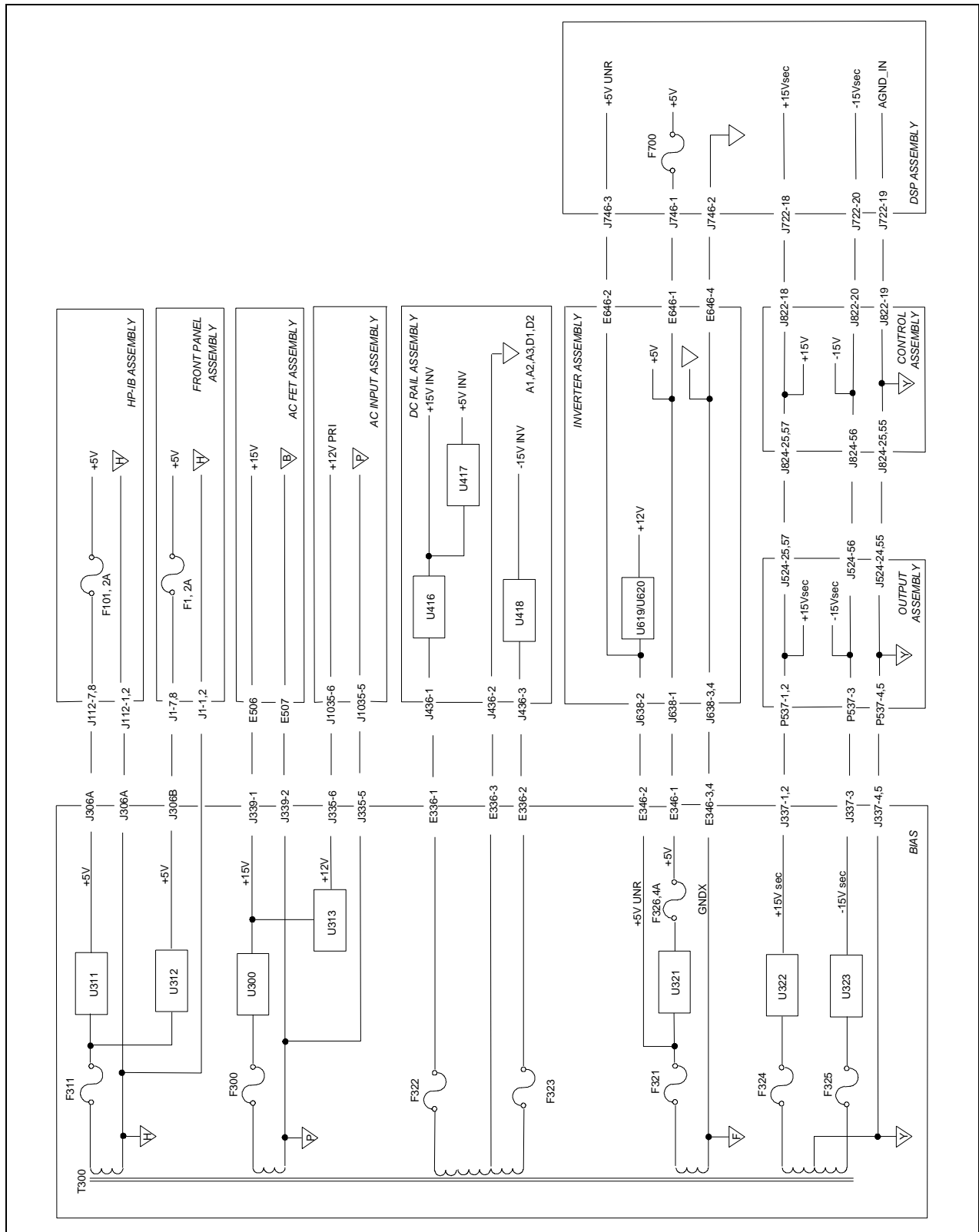

Figure 4-6. Bias Assembly Voltage Distribution

A7 Inverter Assembly Troubleshooting

NOTE: Power FETS 601 through Q608 and Q611 through Q618 should be matched by manufacturer and date code. If any are replaced, they should be mounted using a torque driver set for 5 inch/pounds.

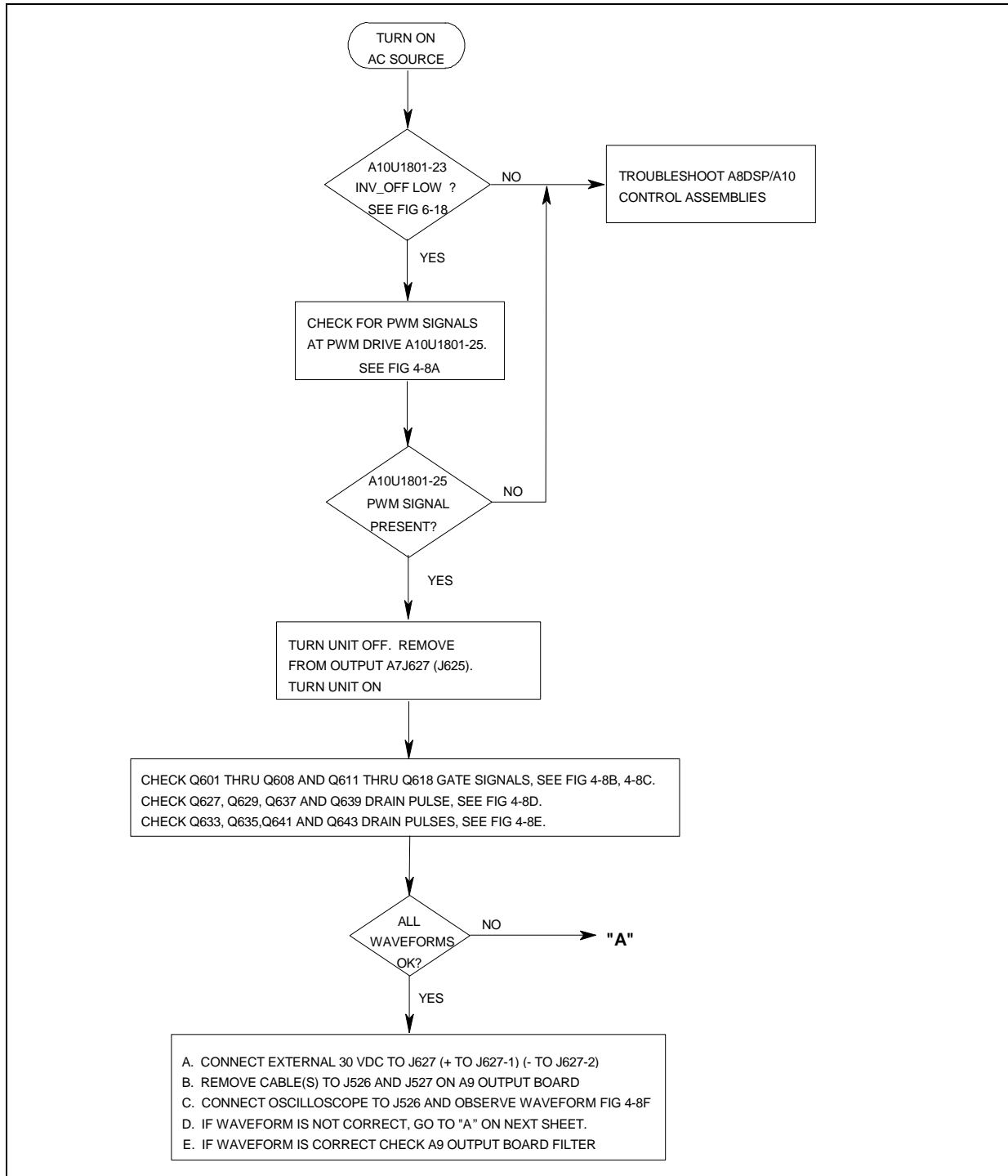

Figure 4-7. Inverter Assembly Troubleshooting (sheet 1 of 2)

4 - Troubleshooting

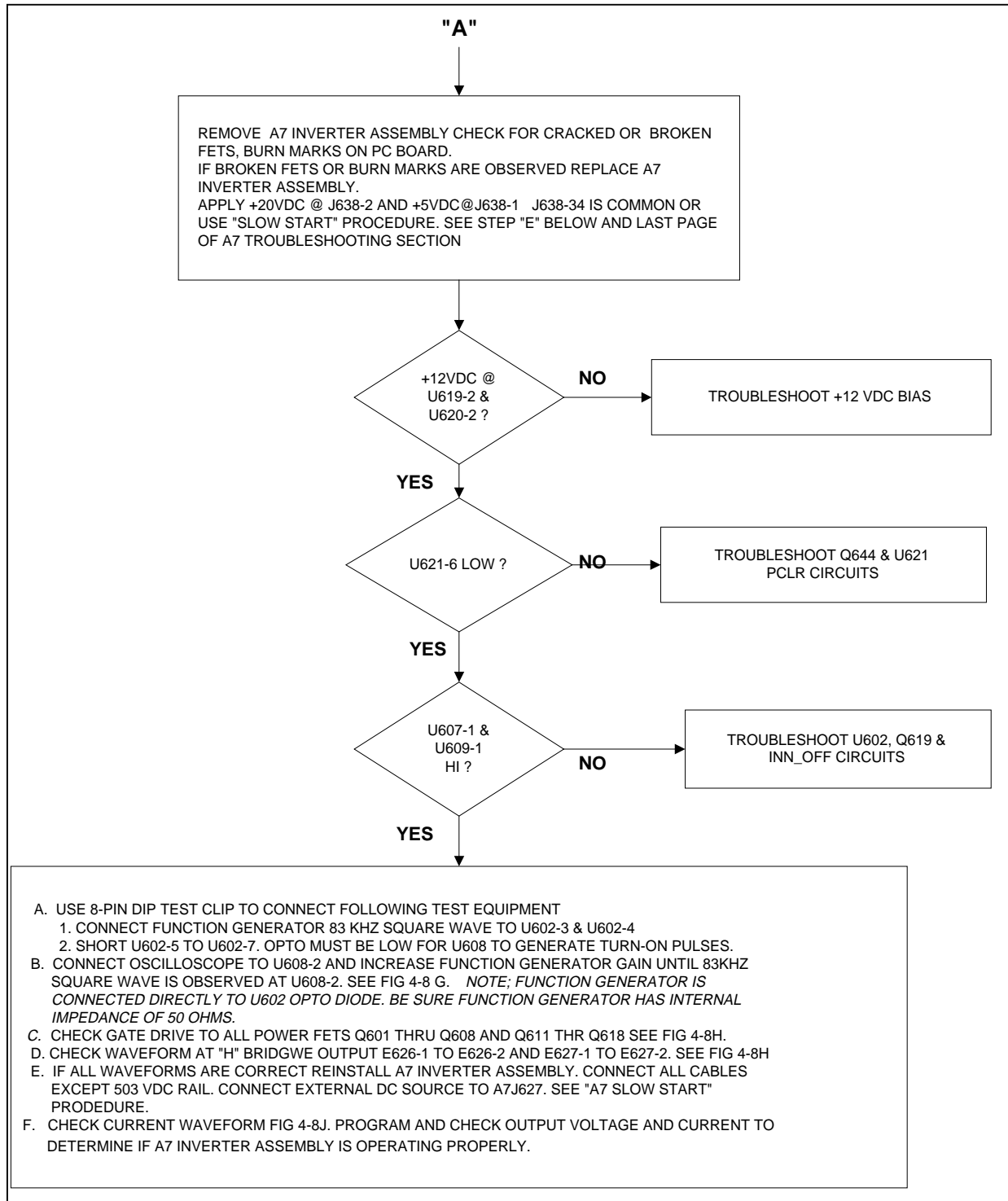

Figure 4-7. Inverter Assembly Troubleshooting (sheet 2 of 2)

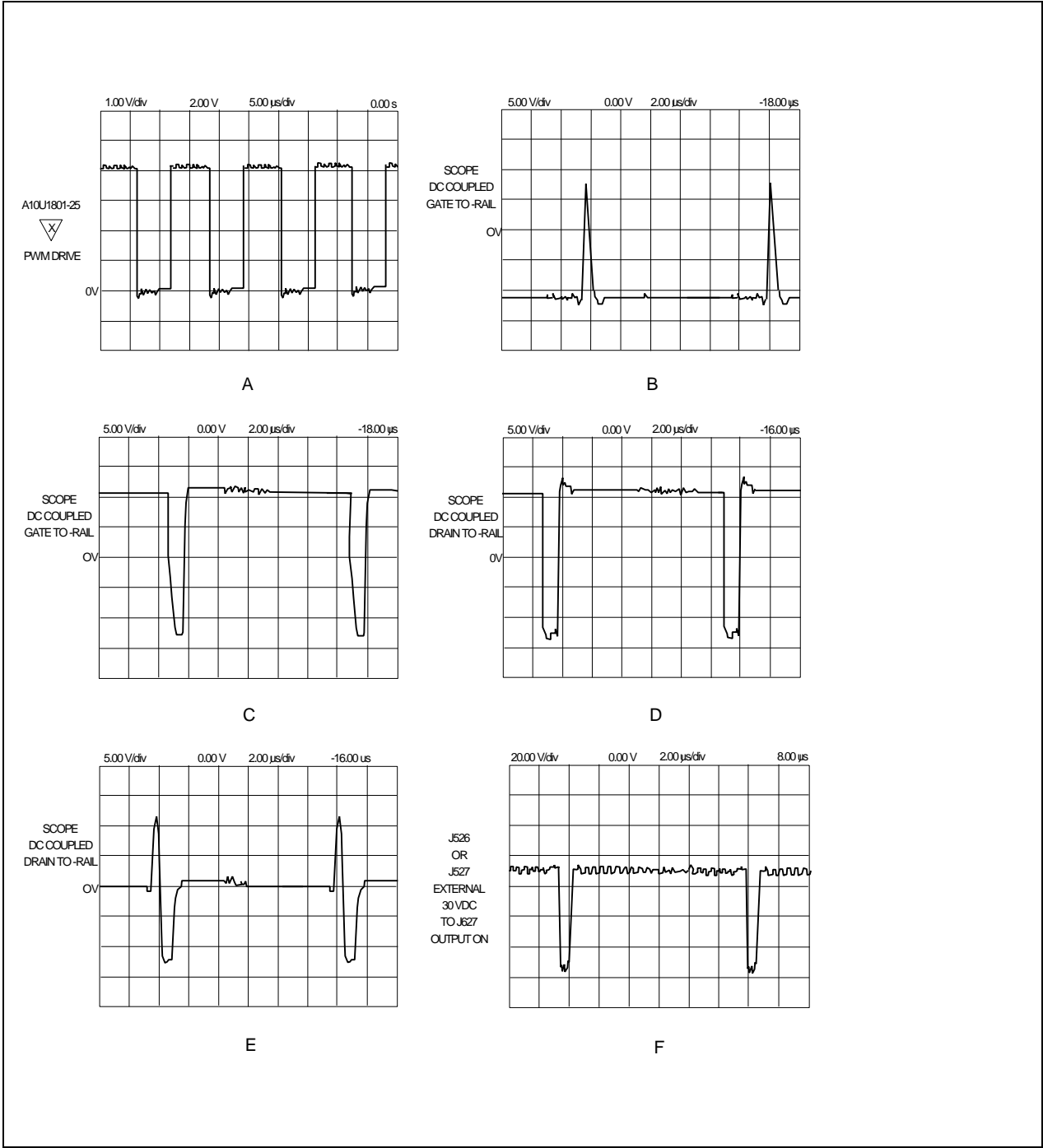

Figure 4-8. Inverter Assembly - Test Waveforms (sheet 1 of 2)

4 - Troubleshooting

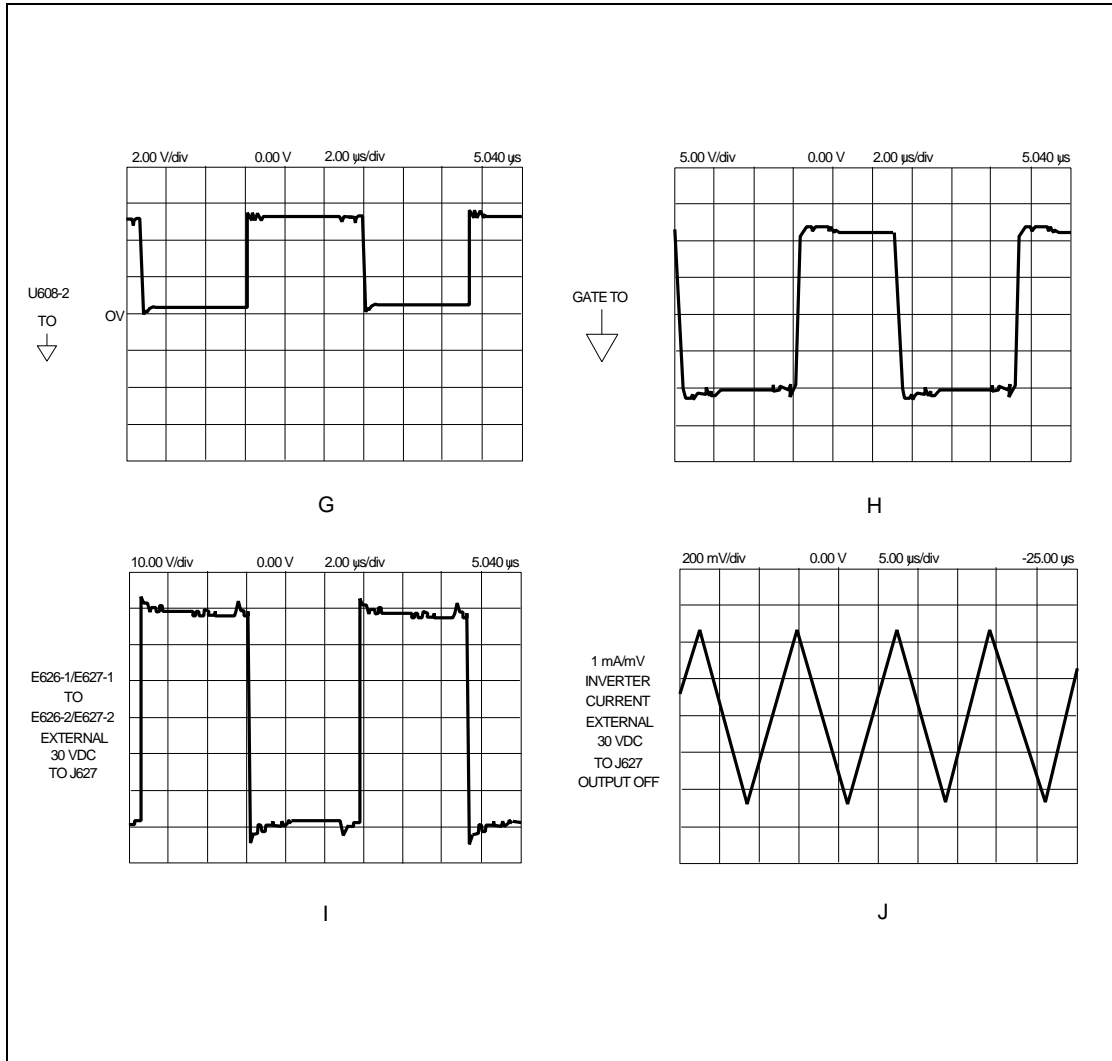

Figure 4-8. Inverter Assembly - Test Waveforms (sheet 2 of 2)

Slow-Start Procedure

Perform the overall A7 inverter troubleshooting documented in Figure 4-7 before you perform the slow-start procedure.

The A7 *Slow-Start* troubleshooting procedure allows testing the A7 inverter assembly and A10 control assembly voltage and current loops using an external DC power supply in place of the AC source 500 Vdc rail. Service Kit 5063-2330 will be required to perform both procedures.

1. Turn off the UUT (AC source) and remove cable 06813-80005 from A7-J627. This cable disconnects the 500 Vdc rail from the A7 Inverter assembly.

WARNING: **SHOCK HAZARD.** Unless you perform step #2, the 500 Vdc rail will still be present on the A5 dc rail assembly during the slow-start procedure.

2. To disable the 500 Vdc rail during the following tests, disconnect cable 5080-2365 from A5-J400. This will remove the PWM drive to the A3 AC FET assembly and disable the 500 Vdc rail. Then connect a jumper from A5-J445-4 to A5-J445-10. This disables the RAIL_LOW_FAULT signal and allows the DSP assembly to function.
3. Use the extender board from the service kit and raise the A8 DSP and A10 Control assemblies from the unit. Verify that the A8 and A10 assemblies are functioning properly. Refer to the A8 DSP and A10 Control assembly troubleshooting procedures.
4. If the A8 DSP and A10 Control assemblies check good, turn off the unit and re-install the A8 and A10 assemblies in the unit.
5. Using cable 5080-2381 supplied in the service kit connect an external (60V/2A minimum) DC power supply to the A7 Inverter assembly A7-J627.
6. Turn on the unit and DC power supply.
7. Set the external DC supply for 0 volts and 2 amps current limit.
8. Slowly increase the external DC supply voltage to 60 Vdc observing the current from the external supply. The external supply should go to 60 Vdc with only 200 to 300 milliamperes current from the external supply. If the current raises immediately check for shorted FETs on the A7 Inverter assembly.
9. Connect an oscilloscope to the unit's output terminal block. Enable the output. Using the front panel knob, increase the output voltage while observing the oscilloscope. A harmonic free sine wave should appear on the oscilloscope until the output voltage reaches approximately 30-35 volts. At this time the sine wave will develop a flat top. This test verifies the voltage control loop.
10. Disable the output and connect a load resistor (20 ohms) capable of sinking 1.5 to 2 amps to the output terminals of the unit.
11. Enable the output and set CURR:LEV to 1 amp. The unit should current limit at 1 ampere and the CC annunciator should come on. The response of the RMS (CURR:LEV) loop is slow so you will have to wait a moment. Set the CURR:LEV to 3 amps and set CURR:PEAK to 1 amp. Both the CV and CC annunciators should come on. These tests verify both the RMS and PEAK current loops.
12. If the A7 Inverter assembly passes the above tests, the voltage and current PWM loops are functioning properly. If the A7 assembly fails when the internal 500 Vdc rail is applied it may be due to high voltage breakdown on either FETs or capacitors on the A7 assembly or the A9 output assembly.

A8 DSP and A10 Control Assembly Troubleshooting

WARNING: When troubleshooting the A8 DSP board and the A10 Control board, disconnect the 500V dc rail between the A9 Output board and the A7 Inverter board by disconnecting the cable from J627. Also, place an insulator over the DC Rail board.

NOTE: To troubleshoot the A8 DSP board and the A10 Control board, it is recommended to use the extender board from Service Kit 5063-2330. The extender raises the A8 and A10 boards from the unit to access the J822/J722 and the J864 connectors.

Table 4-7 lists the general troubleshooting procedure. All analog voltage levels or digital signals can be generated using the front panel keypad. Use an oscilloscope to easily distinguish the ac rms measurements from the dc measurements. Tables 4-8 and 4-9 describe the expected input/output signals between the DSP and the Control boards.

Table 4-7. DSP/Control Assembly Troubleshooting

Step	Procedure	Result																		
With the cable to J627 disconnected																				
1	To check the J822 analog voltages, enter the following commands from the front panel: VOLTAGE VOLT 300 ENTER OUTPUT ON	<table border="0"> <tr> <td>J822-31 -3.8 Vdc</td> <td>J822-32 -0.8 Vdc</td> </tr> <tr> <td>J822-23 +1.0 Vac</td> <td>J822-22 +5.0 Vdc</td> </tr> <tr> <td>J822-15 -4.0 Vdc</td> <td>J822-20 -15.0 Vdc</td> </tr> <tr> <td>J822-13 +6.0 Vdc</td> <td>J822-18 +15.0 Vdc</td> </tr> <tr> <td>J822-9 -2.5 Vdc</td> <td>J822-16 -1.5 Vdc</td> </tr> <tr> <td>J822-5 +3.0 Vac</td> <td>J822-12 -5.0 Vdc</td> </tr> <tr> <td>J822-1 0 Vac</td> <td>J822-10 +6.0 Vdc</td> </tr> <tr> <td></td> <td>J822-8 +5.0 Vdc</td> </tr> <tr> <td></td> <td>J822-6 +6.0 Vdc</td> </tr> </table>	J822-31 -3.8 Vdc	J822-32 -0.8 Vdc	J822-23 +1.0 Vac	J822-22 +5.0 Vdc	J822-15 -4.0 Vdc	J822-20 -15.0 Vdc	J822-13 +6.0 Vdc	J822-18 +15.0 Vdc	J822-9 -2.5 Vdc	J822-16 -1.5 Vdc	J822-5 +3.0 Vac	J822-12 -5.0 Vdc	J822-1 0 Vac	J822-10 +6.0 Vdc		J822-8 +5.0 Vdc		J822-6 +6.0 Vdc
J822-31 -3.8 Vdc	J822-32 -0.8 Vdc																			
J822-23 +1.0 Vac	J822-22 +5.0 Vdc																			
J822-15 -4.0 Vdc	J822-20 -15.0 Vdc																			
J822-13 +6.0 Vdc	J822-18 +15.0 Vdc																			
J822-9 -2.5 Vdc	J822-16 -1.5 Vdc																			
J822-5 +3.0 Vac	J822-12 -5.0 Vdc																			
J822-1 0 Vac	J822-10 +6.0 Vdc																			
	J822-8 +5.0 Vdc																			
	J822-6 +6.0 Vdc																			
2	To check the J822 offset voltages, enter the following commands from the front panel: SHIFT OUTPUT OUTP:COUP DC ENTER VOLTAGE OFFSET 425 ENTER OUTPUT ON VOLTAGE OFFSET -425 ENTER SHIFT OUTPUT *RST ENTER	<table border="0"> <tr> <td>J822-9 -4.6 Vdc (for +425 Vout)</td> </tr> <tr> <td>J822-9 near 0 V (for -425 Vout)</td> </tr> </table>	J822-9 -4.6 Vdc (for +425 Vout)	J822-9 near 0 V (for -425 Vout)																
J822-9 -4.6 Vdc (for +425 Vout)																				
J822-9 near 0 V (for -425 Vout)																				
With the cable to J627 connected so that the ac source can output voltage and current																				
3	Enter the following commands from the front panel: VOLTAGE VOLT 300 ENTER OUTPUT ON VOLTAGE ALC:DET RMS ENTER VOLTAGE VOLT 0 ENTER SHIFT OUTPUT *RST ENTER	<table border="0"> <tr> <td>J822-1 3 Vac</td> </tr> <tr> <td>J822-12 -3.0 Vdc</td> </tr> <tr> <td>J822-12 near 0 V</td> </tr> </table>	J822-1 3 Vac	J822-12 -3.0 Vdc	J822-12 near 0 V															
J822-1 3 Vac																				
J822-12 -3.0 Vdc																				
J822-12 near 0 V																				
With a short across the output terminals																				
4	Enter the following commands from the front panel: VOLTAGE VOLT 5 ENTER OUTPUT ON SHIFT CURRENT CURR:LEV 4 ENTER SHIFT OUTPUT *RST ENTER Remove the short from across the output terminals	<table border="0"> <tr> <td>J822-3 -0.75 Vac</td> </tr> <tr> <td>J822-3 -0.23 Vac</td> </tr> </table>	J822-3 -0.75 Vac	J822-3 -0.23 Vac																
J822-3 -0.75 Vac																				
J822-3 -0.23 Vac																				

Table 4-8. Voltage Measurements at J822 (viewed from circuit side of A10 control board)

range	signal	pin	pin	signal	range
5 to 0.02V	waveform trim	33	34	Z inductance program	-0.1 to 2.5V = 20 to 1000 μ H
0.8 to 4.9V ,normally 3.8V	HS_MON	31	32	fan monitor	0.5 to 2V(0 - 100% fan speed) normally 0.7 to 1V
0V = 0A out; 4.9V = 85A out	I_MON_RMS	29	30	VA monitor	0 to 4.98V
-2.5 to 2.4V	ramp trim	27	28	8-bit DAC common	
	Z DAC reference	25	26	Z resistance program	0 to 2.5V = 0 to 1 Ω
see bias troubleshooting	FAN_PROG	23	24	DC trim	-2.5 to 2.4V
-2.5 to 2.5V	rms voltage trim	21	22	OV program	5 to 0.02V = 448 to 2V pk out
	bias common	19	20	-15V bias	
	rms current common	17	18	+15V bias	
0V = 0A out; -4.99V = 13A out	I_RMS_PROG	15	16	I_PEAK_PROG	-4.99Vdc = 0 to 40 or 80Apeak out
0 to 5V	rms voltage modu	13	14	rms voltage prog. common	
	DC program common	11	12	V_RMS_PROG	0V = 0V out; -3V = 300V out ALC:RTIME = always -4.9V
-4.99 to 0V = -425V to +425V out	WFDC_PROG	9	10	waveform DC modu	0 to 5V
	waveform ampl. common	7	8	waveform DC offset	0 to 5V
0V = 0V out; 3V = 300V out	WFAC_PROG	5	6	waveform ac modu	0 to 5V
-5 to 4.99V ac/dc = full current output	current monitor	3	4	current monitor common	
-5 to 4.99V ac/dc = +/-425Vdc or 300Vac	voltage monitor	1	2	voltage monitor common	

4 - Troubleshooting

Table 4-9. Voltage Measurements at J821 (viewed from circuit side of A10 control board)

range	signal	pin	pin	signal	range
hi	SUB_A2	33	34	DDS down	
hi	SUB_A0	31	32	SUB_A1	normally hi
	+5 volt bias	29	30	digital common (D10 & X)	
normally hi; low true	RESET	27	28	INPUT_RELAY	1.5V @ 10 seconds after power-on
normally low	SUB_ENB	25	26	PCLR	normally hi; low true
ALC:INT = low; ALC:EXT = hi	SENSE_RELAY	23	24	SUB_D	normally low
	+5 volt bias	21	22	OUTPUT_RELAY	output enabled = 4.95 V output disabled = 2 mV
normally hi; low true	INHIBIT	19	20	PROT_CLEAR	pulses hi @ PROT CLEAR
normally low; hi true	RAIL_INHIBIT	17	18	IPCL_Test	
normally low	VA_LIMIT	15	16	REG_FAULT	normally hi
	digital common (D10)	13	14	AC_FAULT_MODE	normally low
normally hi; low true	SOA_FAULT	11	12	SPARE_IN	
normally low; hi true	RAIL_LO_FAULT	9	10	RAIL_LO_WARN	not used
normally hi; low true	DIODE_R_PCLR	7	8	RAIL_HI_FAULT	normally low; hi true
	digital common (D10)	5	6	CV_REALTIME	RMS = low; RTIME = hi
hi when CC true	CL_RMS	3	4	CL_PEAK	normally high; pulsing low true
normally low; hi true	OVP_FAULT	1	2	CV_LEVELING	RMS = hi; RTIME = low

A9 Output/Filter/Relay Assembly Troubleshooting

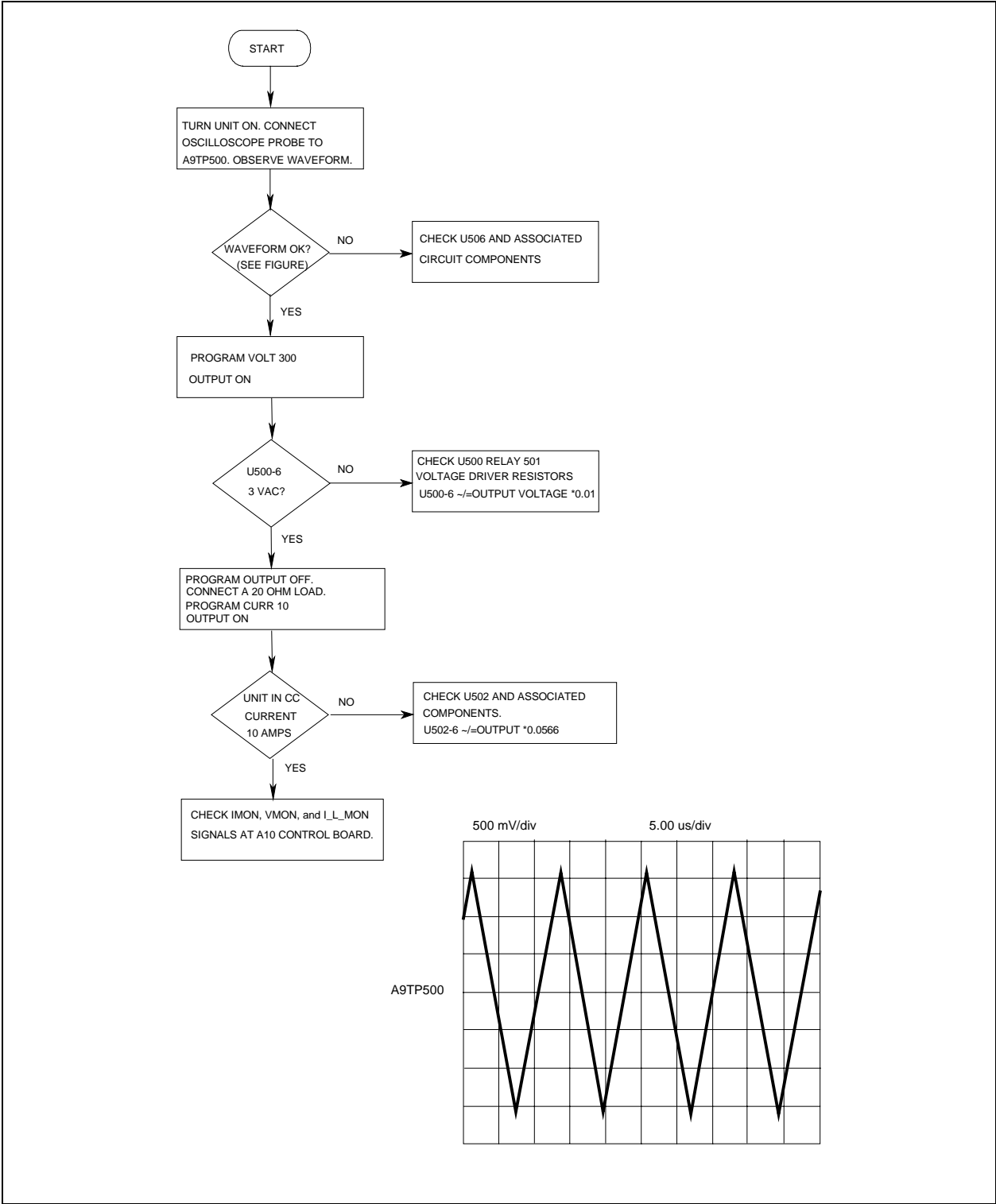

Figure 4-9. Output/Filter/Relay Troubleshooting

A11 Trigger/BNC Board Troubleshooting

Table 4-10. Trigger/BNC Board Troubleshooting

Step	Procedure	Result						
Communications Troubleshooting								
1.	Turn on unit with no voltage or current programmed, and the output off. Use an oscilloscope and check for pulses at U150-1, U151-5, U153-3, and U154-1.	See Figure 4-10A, B, C, D. As long as waveforms are similar, communications are OK. A problem exists if waveforms never go high or low.						
Trigger Out Troubleshooting								
1.	Connect an oscilloscope to the Trig Out BNC and enter the following front panel commands: SHIFT OUTPUT TTL:STATE ON ENTER TRIGGER CONTROL INIT:CONT ENTER Then enter SHIFT TRIGGER .	Check for a trigger output pulse every time the SHIFT TRIGGER command is entered (see Figure 4-10E).						
2.	If no output is observed, trace the signal from the A8 DSP board at: A11 U165-12 A11 U157-12/U165-13 A11 U165-12/U164-10 A11 U164-11	Negative pulse (referenced to H common) Positive pulse (referenced to H common) Positive pulse (referenced to D common) Negative pulse (referenced to D common)						
Trigger In Troubleshooting								
1.	Connect an oscilloscope to the Trig Out BNC and enter the following front panel commands: SHIFT OUTPUT TTL:STATE ON ENTER TRIGGER CONTROL INIT:CONT ENTER TRIGGER CONTROL TRIG:SOUR EXT ENTER Then short the Trig In BNC (pull low).	Check for a trigger output pulse every time the Trig In BNC is shorted (see Figure 4-10E).						
2.	If no output is observed, trace the signal from the A8 DSP board at: A11 U165-12 A11 U157-12/U165-13 A11 U165-12/U164-10 A11 U164-11	Negative pulse (referenced to H common) Positive pulse (referenced to H common) Positive pulse (referenced to D common) Negative pulse (referenced to D common)						
RI (Remote Inhibit) Troubleshooting								
1.	Enter the following front panel commands: VOLTAGE VOLT 100 ENTER OUTPUT ON	100 Vac at the output terminals						
2.	Short the RI terminals together (J113-3 to J113-4).	Output goes to 0 Vac; Output relay opens; PROT annunciator comes on						
3.	If the output does not disable, trace the signal from the A8 DSP board at the following locations: A11 U165-6 A11 U161-5	<table border="0"> <tr> <td><u>Normal</u></td> <td><u>RI Shorted</u></td> </tr> <tr> <td>LOW</td> <td>HI</td> </tr> <tr> <td>HI</td> <td>LOW</td> </tr> </table>	<u>Normal</u>	<u>RI Shorted</u>	LOW	HI	HI	LOW
<u>Normal</u>	<u>RI Shorted</u>							
LOW	HI							
HI	LOW							
DFI (Discrete Fault Indicator) Troubleshooting								
1	Connect a +5 Vdc source to the DFI terminals via a 5K resistor.	See Figure 4-10F.						
2	Connect a controller to the HP-IB connector and send the following HP-IB commands: OUTPUT 705;"OUTP:DFI ON" OUTPUT 705;"OUTP:SOUR:QUES" OUTPUT 705;"STAT:QUES:ENAB 512"							

Table 4-10. Trigger/BNC Board Troubleshooting - continued

Step	Procedure	Result						
3	Connect a voltmeter between J113-1 and J113-2.	Voltmeter should read +5 Vdc						
4	Short the RI terminals together (J113-3 to J113-4).	Voltmeter should read LOW (<0.07 Vdc)						
5	Enter the following front panel commands: SHIFT STATUS QUES:EVEN? ENTER	Voltmeter should read HIGH (+5 Vdc)						
6	If J113-1 does not go low, trace the signal from the A8 DSP board at the following locations: A11 U164-13/U165-3 A11 U164-12/U165-4	<table border="0"> <tr> <td><u>Normal</u></td> <td><u>DFI True</u></td> </tr> <tr> <td>+5 Vdc</td> <td>LOW</td> </tr> <tr> <td>LOW</td> <td>+5 Vdc</td> </tr> </table>	<u>Normal</u>	<u>DFI True</u>	+5 Vdc	LOW	LOW	+5 Vdc
<u>Normal</u>	<u>DFI True</u>							
+5 Vdc	LOW							
LOW	+5 Vdc							

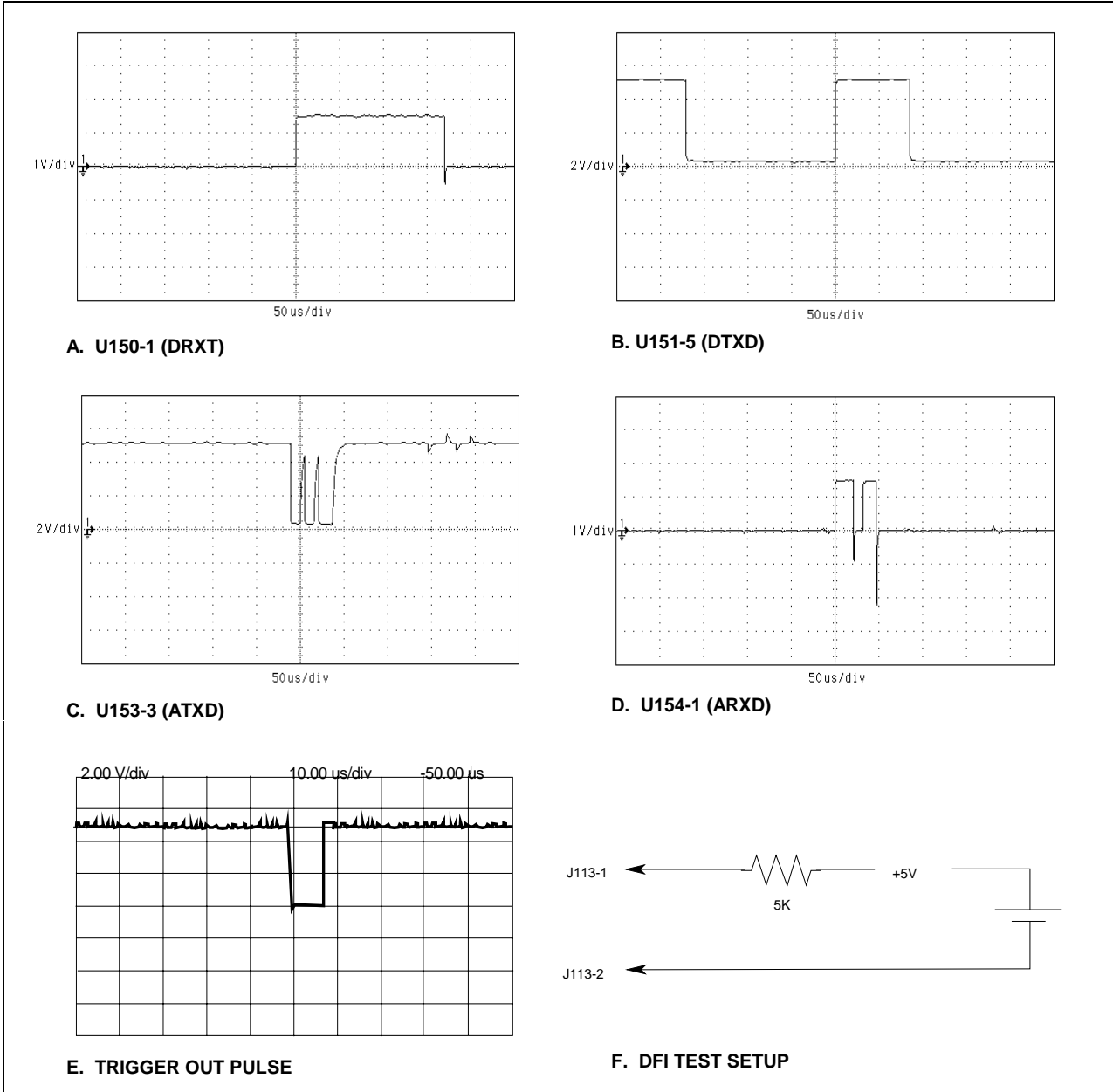

Figure 4-10. Trigger/BNC Assembly - Test Waveforms

Initialization

NOTE: Initializing the unit erases all calibration, waveform, and list data

Instruments that are being initialized for the first time or have suffered non-volatile memory corruption should be initialized with the front panel **EEINIT** command. To initialize the unit perform the following:

1. Turn the unit on, then do the front panel **CAL ON** command.
2. Press **0** and **9** keys simultaneously, **EEINIT <model>** should now be displayed.
3. Scroll to the correct model number and press **ENTER**.

If the command is successful, the front panel display will go through a normal power-on sequence.

ROM Upgrade

Identifying the Firmware

The model number, then firmware revision is displayed on the front panel for approximately 10 seconds when AC line switch is turned on. The firmware revision is also accessible via the HP-IB using the *IDN? query. The following sample HPBASIC program does this.

```
10 ALLOCATE L$[52]
20 OUTPUT 705;"*IDN?"
30 ENTER 705;L$
40 DISP L$
50 END
```

The computer will display the string "**HEWLETT-PACKARD,<model >,0,<revision>**".

Upgrade Procedure

It is possible to update to newer ROM versions without destroying the calibration data. To update the unit to newer ROM revisions perform the following.

1. Turn input power off, remove the old ROMs and install the new ROMS.
2. Turn the unit on, then do the front panel **CAL ON** command.
3. Press **0** and **9** keys simultaneously, then scroll to the **ROMUPD** command.
4. Scroll to the correct model number and press **ENTER**.

If the command is successful, the front panel display will go through a normal power-on sequence. If "OUT OF RANGE" error is displayed, then the instrument will have to be re-initialized with the **EEINIT** command and re-calibrated. This can occur if the instrument was previously initialized with a QA firmware revision (QA.xx.xx), or if non-volatile memory has become corrupted for any reason.

Post-repair Calibration

Calibration is required annually and whenever certain components are replaced. If components in any of the circuits listed below are replaced, the supply must be re-calibrated as described in Appendix B of the User's Guide.

- a. A8 DSP Assembly
- b. A9 Output Filter/Relay Assembly
- c. A10 Control Assembly

If the A8 DSP Assembly is replaced, the supply must be initialized first (see "Initialization" previously discussed in this chapter) and then be calibrated.

Inhibit Calibration Switch

If "CAL DENIED" appears on the display when calibration is attempted, or if error code 401 occurs when calibrating over the HP-IB, the internal INHIBIT CAL switch has been set. This switch setting prevents unauthorized or inadvertent power supply calibration. You must reset this switch in order to calibrate the supply.

The internal calibration switches are located on the A8 DSP board and are accessible by removing the top cover, inner cover then lifting the A10 control board and A8 DSP board assembly. Switches 1 and 2 set the calibration configuration. The three switch positions are illustrated as follows:

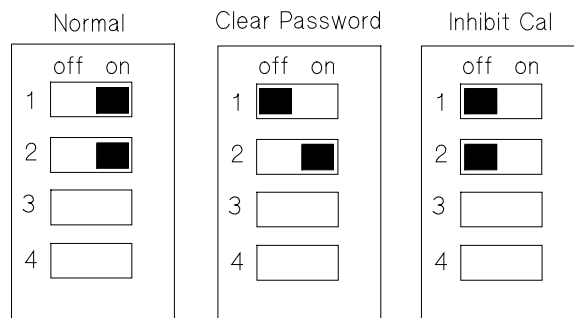

Figure 4-11. Calibration Switches

Normal This is the default switch position. The calibration functions are accessible after entering a numeric password. The default password is 0 and is changeable by the user.

Clear Password The calibration password is reset to 0 and the remote programming language is set to SCPI. This option is useful if the user has forgotten the password.

Inhibit Cal In this position the calibration of the power source cannot be changed. All calibration commands are disabled. If the CAL ON command is sent with the switch in this position an *Out Of Range* error will be displayed on the front panel. This option is useful in installations where calibration access is guarded by instrument seals.

Disassembly Procedures

The following paragraphs provide instructions on how to disassemble various components of the ac source. Once disassembled, the components can be reassembled by performing the disassembly instructions in reverse order. Figure 4-12 shows the location of the major components of the unit.

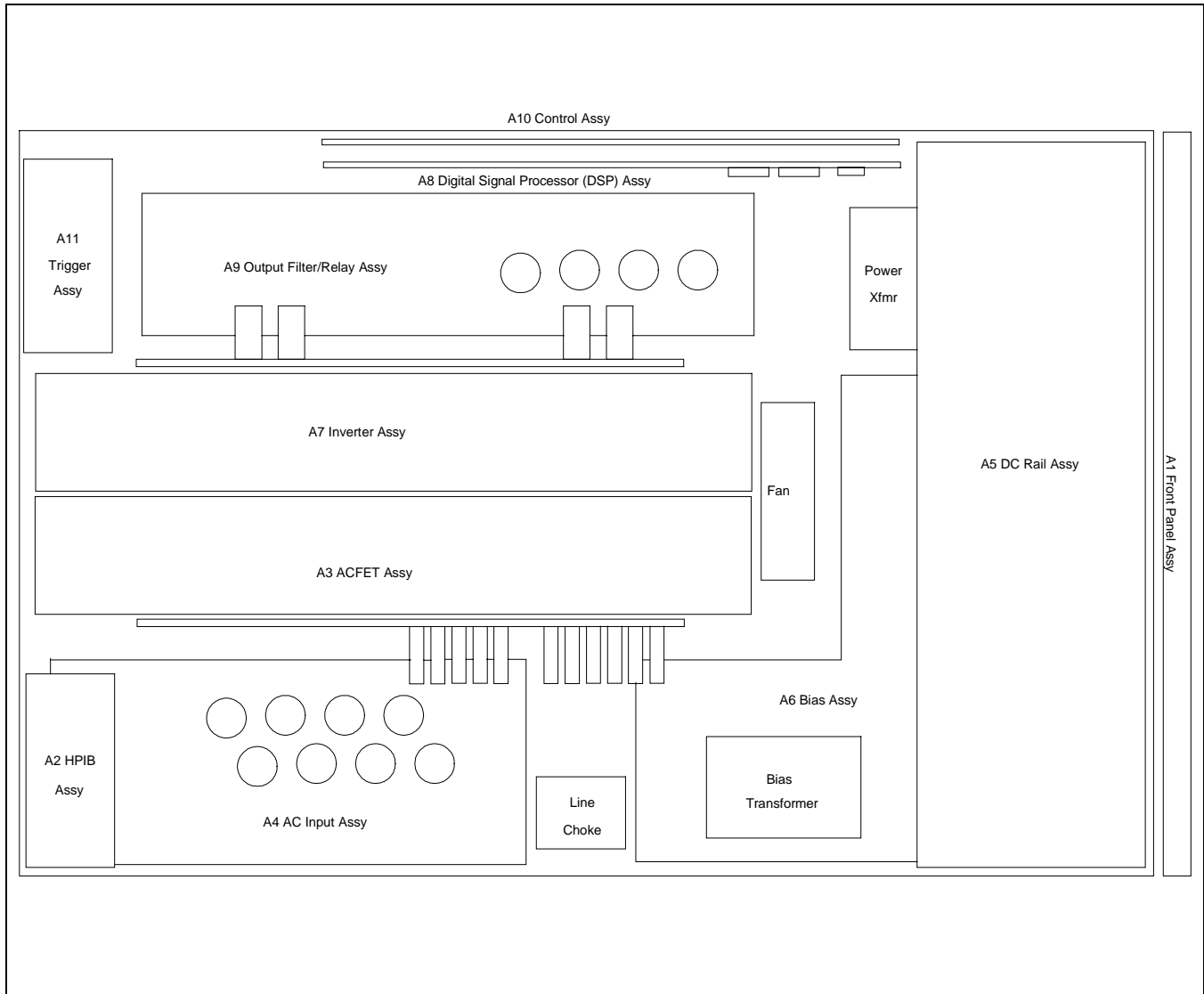

Figure 4-12. Component Locations

WARNING: *SHOCK HAZARD.* To avoid the possibility of personal injury, turn off AC power and disconnect the line cord before removing the top cover. Disconnect the HP-IB cable, any loads and remote sense leads before attempting disassembly.

CAUTION: Most of the attaching hardware is metric. Use of other types of fasteners will damage threaded inserts. Refer to list of required tools when performing disassembly and replacement.

List of Required Tools

- T10, T15 and T25 Torx screwdrivers.
- Allen wrench 0.050 inch.
- 2PT. pozidriv screwdriver
- #2 Phillips screwdriver.
- 3/16 inch flat blade screwdriver.
- 7mm and 10mm Hex drivers
- 5/8 inch Hex driver or box wrench
- Static free workstation and antistatic wrist discharge strap.

Top Cover (outer cover) Removal

- a. Using a T25 Torx screwdriver remove the screws holding the carrying straps on each side of the AC source. Total of 4 screws.
- b. To remove, slide cover toward rear of unit to disengage it from front panel, spread bottom of cover to lift it from the unit.
- c. When replacing the outer cover carefully align front of cover with front frame and rear bottom corners with rectangular blocks mounted on the chassis.

Inner Top Cover Removal

- a. Using a T15 Torx screwdriver remove 4 screws holding the top of the inner cover, 3 screws holding the left side and 4 screws holding the right side.
- b. Lift the inner cover straight up and off the unit.

A1 Front Frame / Panel Assembly Removal and Replacement

- a. Remove the top cover as described earlier.
- b. Locate and carefully peel off the vinyl trim strips (one on each side of the frame) to gain access to the side screws that secure the front frame to the chassis.
- c. Using a T10 Torx screwdriver remove 2 screws from each side of the front frame.
- d. Move the front frame forward a few inches and disconnect the phone type cable from connector A1J6 located on the front panel PC board.
- e. Move the right side of the front frame forward, pivoting on the left corner to gain access to S1 on / off switch.
- f. Disconnect the wires going to switch S1 noting the color code of the wires and the respective switch terminals to which they connect for subsequent reconnection.
- g. The front frame can now be removed from the AC source.
- h. To remove the PC board from the front frame, use a T10 Torx to remove the screw. Find the PC board finger that keeps the PC board from sliding in the direction of switch S1. Lift the PC board finger, slide the PC board off the plastic fingers and remove the PC board from the frame.
- j. To reinstall the front panel PC board and front frame perform the above steps in reverse order.

4 - Troubleshooting

A2 HI-IB / RS 232 Board Removal and Replacement

- a. Remove the outer and inner top covers as described earlier.
- b. Remove the two (2) 7 mm Hex screws that hold the HP-IB connector place.
- c. Using a T15 Torx screwdriver remove the screw holding the PC board to the rear chassis.
- d. Disconnect the phone type cable from J112.
- e. To reinstall the A2 HP-IB PC board perform the above steps in reverse order.

A3 AC FET Assembly Removal and Replacement

- a. Remove the outer and inner top covers as described earlier.
- b. Remove DC rail cable from A4J1042 on AC input board.
- c. Remove bias cables between A3J200 and A5J400 on A5 DC rail board and from A6J339 on the A6 bias board.
- d. Lift fan straight up from unit and rest on A5 DC rail board.
- e. Remove Litz wire cables from power transformer that connect to TB201 on A3 assembly.
- f. Use T15 Torx screwdriver to remove screw holding A3 ACFET assembly to rear panel.
- g. Slide A3ACFET assembly toward front of AC source and lift assembly up and out of unit.
- h. To reinstall the A3 ACFET assembly, perform the above steps in reverse order.

A4 AC Input Board Removal and Replacement

- a. Remove the outer and inner top covers as described earlier.
- b. Remove the A2 HPIB board as described earlier.
- c. Remove the A3 ACFET assembly as described earlier.
- d. Use 10mm Hex driver to disconnect ground wire connected to rear panel, located under A2 HPIB board.
- e. Remove red and black wires going to line choke.
- f. Remove cable between J1035 and J335 on A6 Bias board.
- g. Using a T15 Torx screwdriver, remove 3 screws holding A4 AC Input board to chassis.
- h. Slide A4 AC Input board toward the front of the unit and lift from chassis.
- j. To reinstall the A4 AC Input board perform the above steps in reverse order.

A5 DC Rail Board Removal and Replacement

- a. Remove the outer and inner top covers as described earlier.
- b. Disconnect cables at J436, J400, J444 and J445.
- c. Using T15 Torx screwdriver remove 5 screws holding A5 DC rail board to chassis.
- d. Disconnect cable to J1232 or J1233 on power transformer board. Mark which connector the cable was removed from.
- e. Disconnect wires from rail choke 5080-2329 at A5 DC rail board. The A5 DC rail board is labled with wire color code.
- f. To reinstall the A5 DC rail board perform the above steps in reverse order taking care to reconnect the rail choke wires to the correct terminals and the power transformer cable to the correct receptable.

A6 Bias Board Removal and Replacement

- a. Remove the outer and inner top covers as described earlier.
- b. Remove A5 DC rail board as described earlier.
- c. Disconnect cables from J306A, J306B, J335, J337, J339 and J343.
- d. Disconnect wires going to S1 on/off switch. Record where wires terminate at switch.
- e. Using T15 Torx screwdriver remove 1 screw holding A6 bias board to chassis.
- f. Using 2PT posidrive screwdriver remove 4 screws holding bias transformer and A6 bias board to chassis.
- h. Slide A6 bias board to the left and lift from chassis.
- j. To reinstall the A6 Bias board perform the above steps in reverse order.

A7 Inverter Assembly Removal and Replacement

- a. Remove outer and inner top covers as described earlier.
- b. Lift fan out of chassis and rest on A5 dc rail board.
- c. Disconnect cables to J526 and J527 on A9 output board.
- d. Disconnect cables to J627 from A9 output board and J638 from A6 bias board.
- e. Disconnect cables to J828 and J855 on A10 control board.
- f. Disconnect cable at J444 on A5 DC rail board to help in removal of A7 Inverter assembly.
- g. Using T15 Torx screwdriver remove screw holding A7 Inverter assembly to rear chassis.
- h. Slide A7 Inverter assembly toward front of unit and lift from chassis.
- j. To reinstall the A7 Inverter assembly perform the above steps in reverse order.

A8 DSP Board and A10 Control Board Removal and Replacement

- a. Remove outer and inner top covers as described earlier.
- b. Disconnect cable from A7 Inverter assembly to J746 on the A8 DSP board.
- c. Disconnect cables to J828 and J855 on A10 control board.
- d. Disconnect cable to J115 on the A11 Trigger board.
- e. Using T15 Torx screwdriver remove 3 screws holding A10 Control board to right side of chassis.
- f. Lift A10 Control board from chassis.
- g. Using T15 Torx screwdriver remove 6 screws holding A8 DSP board to A10 Control board.
- h. To reinstall the A8 DSP and A10 control boards perform the above steps in reverse order.

4 - Troubleshooting

A11 Trigger (BNC) Board Removal and Replacement

- a. Remove outer and inner top covers as described earlier.
- b. Disconnect cable from A10 control board to J115.
- c. Disconnect cables to J106 and J112. Mark cables to J106 and J112 before removing. If the cables are reversed during replacement, the ac source will not pass turn-on self test.
- d. Use 5/8 inch socket/box wrench to remove nuts holding BNC connectors to rear panel.
- e. Remove A11 Trigger board from unit.
- j. To reinstall the A11 Trigger (BNC) board perform the above steps in reverse order

A9 Output Board Removal and Replacement

- a. Remove outer and inner top covers as described earlier.
- b. Remove A7 Inverter assembly, A8 DSP, A10 Control and A11 Trigger boards as described earlier.
- c. Disconnect cable going to J337 on the A6 bias board.
- d. Disconnect cable going to J445 on the A5 DC rail board.
- e. Using T15 Torx screwdriver remove 4 screws holding A9 output board to chassis.
- f. Slide A9 output board toward the front of the unit and lift from chassis.
- g. To reinstall the A9 output board perform the above steps in reverse order

Replaceable Parts List

Introduction

This section lists the replaceable electrical and mechanical parts for the the HP Series 6611A/B, 6612A/B, 6613A/B AC Power Source/Analyzers, and HP Series 6841A, 6842A Harmonic Flicker Test Systems.

Reading the Tables

Each table lists electrical components alphabetically by reference designator and provides the HP part number followed by the part description. Mechanical parts are placed after the electrical parts and listed alphabetically by part description. Unless otherwise specified, a listed part is used in all models of the series. Model-specific parts are tabulated by model number under the reference designator.

Note that the word "All" in the Applicability column in any of these tables means that the item is applicable to all models.

Part Reference Designators

A	assembly	K	relay	T	transformer
B	blower (fan)	L	inductor	TB	terminal block
C	capacitor	M	mechanical	U	integrated circuit
CR	thyristor/SCR	P	plug	VR	voltage regulator
D	diode	Q	transistor	W	cable or jumper
DSP	display (LCD)	R	resistor	Y	crystal oscillator
F	fuse	RT	thermal resistor		
J	jack	SW	switch		

Part Description Abbreviations

assy	assembly	m	metric	PCB	pc board	W/	with
bd	board	mch	machine	sq	square	w/o	without
gnd	ground	mm	millimeter	submin	subminiature	xfmr	transformer
lg	long	mtg	mounting	thrd	thread	xtal	crystal

How to Order Parts

You can order parts from your local Hewlett-Packard Sales and Support Office (see the list of offices in the back of this manual). When ordering a part, please include the following information:

the HP part number

the part description

the model number of the unit.

5 - Replaceable Parts

Table 5-1. Parts List for HP 6811A/B, 6812A/B, 6813A/B, 6841A, 6842A Main Assembly

Ref Desig.	Applicability	HP Part No.	Description
TESTED CIRCUIT BOARD ASSEMBLIES			
A1 ¹	All	5060-3596	Front Panel Board Tested
A2	6811A,6812A,6813A	5060-3594	HP-IB/RS-232 Board Tested
A2	6811B,6812B,6813B,6841A,6842A	5063-2376	HP-IB/RS-232 Board Tested
A3	6811A/B,6812A/B,6841A	06812-61001	AC FET Board Tested
A3	6813A/B,6842A	5063-2316	AC FET Board Tested
A4	6811A/B	06811-61020	AC Input Board Tested
A4	6812A/B,6841A	06812-61020	AC Input Board Tested
A4	6813A/B,6842A	06813-61020	AC Input Board Tested
A5	All	5063-2313	DC Rail Board Tested
A6	6811A/B,6812A/B,6841A	06812-61021	Bias Board Tested
A6	6813A/B,6842A	06813-61021	Bias Board Tested
A7	6811A/B,6812A/B,6841A	06812-61023	Inverter Board Tested
A7	6813A/B,6842A	06813-61023	Inverter Board Tested
A8	6811A,6812A,6813A	5063-2315	DSP Board Tested
A8	6811B,6812B,6813B,6841A,6842A	5063-2367	DSP Board Tested
A9	6811A/B	06811-61022	Output/Relay/Filter Board tested
A9	6812A/B,6813A/B,6841A,6842A	5063-2314	Output/Relay/Filter Board Tested
A10	6811A/B	5063-3482	Control Board Tested
A10	6812A/B,6841A	5063-2369	Control Board Tested
A10	6813A/B,6842A	5063-2370	Control Board Tested
A11	All	5060-3597	Trigger (BNC) Board
A12	All	5060-3590	Thermistor Board
	All	9100-5145	Power Transformer Assembly
MECHANICAL PARTS			
M1 ¹	All	5040-1702	KEYPAD - AC SOURCE
M2 ¹	All	5040-1703	FRONT FRAME
M3 ¹	All	5080-2333	WINDOW
M4 ¹	All	5001-6795	FRONT PANEL LABEL
M5 ¹	All	0370-3238	KNOB 6mm
M6 ¹	6811A	06811-80001	NAMEPLATE
	6811B	06811-80007	NAMEPLATE
	6812A	06812-80001	NAMEPLATE
	6812B	06812-80003	NAMEPLATE
	6813A	06813-80001	NAMEPLATE
	6813B	06813-80006	NAMEPLATE
	6841A	06841-80001	NAMEPLATE
	6842A	06842-80001	NAMEPLATE
¹ Refer to	All	0360-2190	JUMPER-BARR BLK
Figure 5-1	All	0360-2191	CVR-TERM BLK-DC
at the end of	All	0515-1085	SCREW DC COVER
this chapter	All	06813-20001	INV HEAT SINK
for location	All	06813-80002	FET PAD INVERTER DFL/RI
information.	All	1252-1488	TERM-BLK- 4 POS
	All	1400-0493	CABLE TIE
	All	1400-0611	CLAMP-CABLE (rail choke)
	All	3101-3088	LINE SWITCH
	All	5001-0539	TRIM SIDES,FR GY
	All	5001-6745	COVER
	All	5001-6799	CHASSIS INVERTER
	All	5001-9801	CHASSIS AC FET

Table 5-1. HP 6811A/B, 6812A/B, 6813A/B, 6841A, 6842A Main Assembly - continued

Ref Desig.	Applicability	HP Part No.	Description
L1050	All	5001-9803	CHASSIS TOP
	All	5001-9804	PANEL-REAR
	All	5001-9805	BRACKET-FAN
	All	5001-9808	FET CLIP
	All	5001-9809	BRACKET DC RAIL
	All	5040-1676	SAF-CVR-AC INPUT
	All	5040-1697	BLOCK-TOP COVER
	All	5040-1704	AC SAFETY COVER
	All	5041-8801	FOOT
	All	5041-8819	CAP-STRAP HANDLE
	All	5041-8820	CAP-STRAP HANDLE
	All	5060-3570	CHASSIS ASSY
	All	5062-3705	STRAP HANDLE
	All	5080-2328	CHOKE-LINE
	All	5080-2329	CHOKE-RAIL
	All	5080-2339	LABEL-REAR PANEL
	All	5080-2341	XFMR INSULATOR
	All	5080-2342	INSULATOR
	All	5080-2348	CABLE ASSEMBLY
	All	5080-2353	CABLE ASSEMBLY
	All	5080-2356	CABLE ASSEMBLY
	All	5080-2362	ASSY-FAN
	All	5080-2365	CABLE
	All	5080-2373	INSULATOR INVERTER
	All	5080-2380	CABLE ASSEMBLY
	All	5080-2381	CABLE ASSEMBLY
	All	5080-2397	CABLE ASSEMBLY
	All	5062-3977	RACK MOUNT KIT (without handles)
	All	5062-3983	RACK MOUNT KIT (with handles)
	All	7120-8214	LABEL-WARNING
	All	7121-2794	LABEL-ID SN
	All	9100-5145	XFMR-SWITCH POWER
	All	8120-5573	PWR CORD OPT 831
	6813A/B,6842A	8120-6502	PWR CORD OPT 832
	6811A/B	8120-8605	POWER CORD OPT 900
	6811A/B	8120-8606	POWER CORD OPT 901
	6811A/B	8120-8607	POWER CORD OPT 902
	6811A/B	8120-8608	POWER CORD OPT 912
	6811A/B	8120-8609	POWER CORD OPT 903, 918
	6811A/B	8120-8610	POWER CORD OPT 904
	6811A/B	8120-8611	POWER CORD OPT 917
	6812A/B,6841A	8120-5568	POWER CORD OPT 833
	6812A/B,6841A	8120-5566	POWER CORD OPT 834.
	6812A/B,6813A/B	8120-6505	POWER CORD/PLUG OPT 841
	6841A,6842A	8120-6505	POWER CORD/PLUG OPT 841
	6813A/B,6842A	8120-6506	POWER CORD OPT 842
	6813A/B,6842A	8120-6507	POWER CORD/PLUG OPT 844
6812A/B,6841A	8120-6508	POWER CORD/PLUG OPT 845	
6812A/B,6841A	8120-6509	POWER CORD/PLUG OPT 846	
6812A/B,6841A	8120-5567	POWER CORD/PLUG OPT 847	
6812A/B,6841A	8120-6511	POWER CORD/PLUG OPT 848	

5 - Replaceable Parts

Table 5-2. Parts List for HP 6811A/B, 6812A/B, 6813A/B, 6841A, 6842A Technical Manuals

Reference Desig.	Applicability	HP Part No.	Description
	All	5962-0885	REFERENCE CARD
	All	5962-0829	GUIDE-USER
	All	5962-0883	GUIDE-QUICK START ENGLISH
	All	5962-0889	GUIDE-PROGRAMMING
	All	5962-0837	GUIDE-QUICK START FRENCH.
	All	5962-0839	GUIDE-QUICK START ITALIAN
	All	5962-0841	GUIDE-QUICK START SPANISH
	All	5962-0843	GUIDE-QUICK START CHINESE (TAIWAN.)
	All	5962-0845	GUIDE-QUICK START KOREAN.
	All	5962-0847	GUIDE-QUICK START GERMAN.
	All	5962-8101	GUIDE-QUICK START JAPANESE
	All	5961-5190	GUIDE-USER JAPANESE
	All	5962-8113	GUIDE -QUICK START CHINESE (PRC)
	All	5962-8115	GUIDE-USER CHINESE (PRC)

Table 5-3. Parts List for HP 6811A/B, 6812A/B, 6813A/B, 6841A, 6842A AC Input Board

Reference Desig.	Applicability	HP Part No.	Description
ELECTRICAL PARTS			
C1010,1011	All	0160-4183	CAP 1000 pF 20%
C1012-1016	All	0160-7606	CAP 1uF 275V
C1020,1021	All	0160-3969	CAP .015 uF 20%
C1022,1023,1080	All	0160-4439	CAP 4700 pF 20%
C1040	All	0160-4355	CAP .01uF 10%
C1050	All	0160-4065	CAP 1uF 20%
C1051,1052	All	0160-7606	CAP 1uF 275V
C1060,1061	6813A/B,6842A	0180-4641	CAP 2700 uF 200V
C1062-1065	6811A/B	0180-4528	CAP 1800 uF 200V
C1062-1065	6812A/B,6841A	0180-4641	CAP 2700 uF 200V
C1066,1067	6813A/B,6842A	0180-4641	CAP 2700 uF 200V
D1060	All	1906-0389	FWB KPC3506/356
D1061	All	1901-1098	DIO-IN4150
DS1080	All	1990-0517	LED-VISIBLE
E1047	6811A/B,6812A/B,6841A	5060-3586	ASSY-WIRE KIT
E1051	All	66000-60051	ASSY-WIRE KIT
F1020	6811A/B,6812A/B,6841A	2110-0910	FUSE 30AM 500V
F1020	6813A/B,6842A	2110-0849	FUSE 25AM 250V
F1080	All	2110-0098	FUSE 20AM 250V
HS1060	All	1205-0861	HEAT SINK
J1035	All	1252-2672	CONN-POST-TP-HDR
J1042	All	1251-4781	CONN-UTIL
J1047	All	1251-5613	CONN-SGL CONN
J1049	All	0360-2421	BARRIER-BLOCK
K1040,1041	All	0490-1834	RLY 1C 12VDC
L1020	6811A/B	06811-80003	CHOKE-INPUT
L1020	6812A/B,6841A	66000-80004	CHOKE-INPUT
L1060,1061	All	06012-80095	CHOKE-OUTPUT
Q1040	All	1855-0665	MOSFET RFP 2N12L
R1010	All	0698-8827	RES 1M 1%.125W
R1040,1041,1045,1046	All	0811-3932	RESISTOR-FIXED
R1042	All	0698-4150	RES 115 1%.25W
R1043,R1044	All	0698-0092	RES 2.61K 1%
R1050	All	0698-3620	RES 100 5% 2W MO
R1051	All	0811-1666	RES 1 5% 2W PW
R1060,1061,1080,1081	All	0811-1866	RES IOK 1% 5W PW
R1082	All	0757-0418	RES 619 1%.125W

Table 5-4. Parts List for HP 6811A/B, 6812A/B, 6813A/B, 6841A, 6842A Bias Board

Reference Desig.	Applicability	HP Part No.	Description
ELECTRICAL PARTS			
C300,311,321,350	All	0160-4834	CAP .047 uF 10%
C301,328	All	0180-3298	C-F 2200uF 50V
C302,313,325,329	All	0180-0230	C-F 1uF 50V
C303,304,314,315,317,C326,327,330	All	0180-4129	CAP 1 uf 35V
C312	All	0180-4137	CAP 1200 uf 35V
C322	All	0180-4462	CAP 1200 uF 63V
C323	All	0180-4398	C-F 470 uf 63V
C324	All	0180-3458	CAP 4700 uF 50V
C331	All	0180-4131	CAP 4.7 uf 35 V
C361	All	0180-4136	CAP 1 uf 20V
D300-303,331-334,351	All	1901-0731	DIO-IN4004/10GO4
D321-324,362-365	All	1901-1087	DIO-PWR 856
D325	All	1901-0992	DIODE 40V 3A
D352	All	1901-1098	DIO-IN4150
E334	All	5080-2355	CABLE
E336	All	5080-2357	CABLE
E338	All	5080-2358	CABLE
F300,322,323	All	2110-0688	FUSE 3AM 125V
F301	All	2110-0002	FUSE 2AM 250V
F311,321	All	2110-0685	FU-SUBMIN 7AM
F324,325	All	2110-0699	FU-SUBMIN 5AM
F326	All	2110-0712	FU-SUBMIN 4AM
HS300,311,312,322,351	All	1205-0350	HEAT SINK
HS321,323	All	1205-0282	HEAT SINK
J306,314	All	1252-1999	MOD PHONE RCPT
J335	All	1252-2672	CONN-POST-TP-HDR
J337	All	1251-8139	CONN-POST-TP-HDR
J339	All	1252-0063	CONN-POST-TP-HDR
J343	All	1252-0055	CONN-POST-TP HDR
J353	All	1251-5439	CONN-POST-TP-HDR
L321	All	5080-2321	CHOKE-OUTPUT
Q351	All	1854-0828	XSTR NPN SI
R300,326,329	All	0698-8672	RES 243.4 .1%
R301	All	0698-0085	RES 2.61K 1%
R311,313	All	0699-0083	RES 681 .1%.1W
R314	All	0699-1982	RES 1.055K . 1%
R323	All	0757-0279	RES 3.16K 1%
R324	All	0757-0280	RES IK 1%.125W
R325	All	8159-0005	RES-ZERO OHMS
R327,328	All	0757-0281	RES 2.74K 1%
R330	All	0699-0208	RES I 5%.25W CF
R351	All	0698-3155	RES 4.64K 1%
R354	All	0686-2225	RES 2.2K 5% .5W
R372	All	0757-0463	RES 82.5K 1%
R373	All	0757-0419	RES 681 1%.125W
T300	6811A/B,6812A/B,6841A	9100-5143	XFMR-BIAS
T300	6813A/B,6842A	9100-5144	XFNR-BIAS
T301	6811A/B,6812A/B,6841A	9100-5141	TRANSFORMER-HPIB
T301	6813A/B,6842A	9100-5142	TRANSFORMER-HPIB
U300,311,312,322	All	1826-0393	IC LM317T
U313	All	1826-0147	IC 7812/34OT-12
U321	All	1826-2505	IC LM2576T-ADJT
U323	All	1826-0527	IC LM337T
U362	All	1990-1074	OPTO-ISOLATOR
VR351	All	1902-0955	DIO-ZNR 7.5V 5%
VR352	All	1902-0957	DIO-ZNR 9.1 V 5%

5 - Replaceable Parts

Table 5-5. Parts List for HP 6811A/B, 6812A/B, 6813A/B, 6841A, 6842A Inverter Board

Reference Desig.	Applicability	HP Part No.	Description
ELECTRICAL PARTS			
C601,605,608,612	All	0160-7929	CAP 100 pF
C621,625,628,632	6813A/B,6842A	0160-7929	CAP 100 pF
C602,606,607,611	All	0160-7640	C-F 330 pF 1600V
C622,626,627,631	6813A/B,6842A	0160-7640	C-F 330 pF 1600V
C603,604,609,610	All	0160-5927	CAP 0.022 uF 400V
C623,624,629,630	6813A/B,6842A	0160-5927	CAP 0.022 uF 400V
C613,614,616	All	0160-7935	CAP 2 uf 600V
C615,618	6813A/B,6842A	0160-7935	CAP 2 uf 600V
C637,643,645,646,	All	0160-5422	CAP .047 uF 20%
C649,651,685,689	All	0160-5422	CAP .047 uF 20%
C641,642	All	0160-0335	CAP 91 pF 1% 300V
C644,684,686	All	0180-0228	C-F 22 uF 15V
C647,648,652,653	All	0160-4801	CAP 100 pF 5%
C661,C664,C670,C673	All	0160-4822	CAP 1000 pF 5%
C663,680	All	0160-3490	CAP 1 uF 20% 50V
C668,677	6813A/B,6842A	0160-3490	CAP 1 uF 20% 50V
C665,666,674,675	All	0160-4803	CAP 68 pF 5% 100V
C669,671,672,678	6813A/B,6842A	0160-4803	CAP 68 pF 5% 100V
C676	6813A/B,6842A	0180-1835	C-F 68 uF 15V
C679	All	0180-1835	C-F 68 uF 15V
C687	All	0180-4397	C-F 100 uf 63V
C688	All	0160-4846	CAP 1500 pf 100V
C690	6813A/B,6842A	0180-0197	C-F 2.2 uF 20V TA
C691	All	0180-0197	C-F 2.2 uF 20V TA
C1601	All	0160-4811	CAP 270 pF 5%
D601,602,607,608	All	1901-1302	DIODE
D615,616,625,626	6813A/B,6842A	1901-1302	DIODE
D603,606,609,612	All	1901-1214	DIO-PWR RECT
D617,620,622,624	6813A/B,6842A	1901-1214	DIO-PWR RECT
D604,605,610,611	All	1901-1152	DIODE-POWER S
D618,619,621,623	6813A/B,6842A	1901-1152	DIODE-POWER S
D631-638	All	1901-0050	DIO-SWITCHING
D639-646	6813A/B,6842A	1901-0050	DIO-SWITCHING
E626,627	All	5080-2351	CABLE
E628	All	5080-2352	CABLE
E646	All	5080-2364	CABLE
J627	All	1251-7616	CONN-UTIL MT-LK
J638	All	1251-3305	CONN-POST-TP-HDR
L601-608	All	9170-1620	BEAD-FERRITE
L611-618	6813A/B,6842A	9170-1620	BEAD-FERRITE
Q601-608	All	1855-0917	MOSFET,N-CHANNEL
Q611-618	6813A/B,6842A	1855-0917	MOSFET,N-CHANNEL
Q619	All	1854-0215	XSTR NPN 2N3904
Q624,625,630,631	All	1855-0725	MOSFET MTF3055E
Q626,628,632,634	All	1855-0934	MOSFET 50V, 5.3
Q636,638,640,642	6813A/B,6842A	1855-0934	MOSFET 50V, 5.3
Q627,629,633,635	All	1855-0549	MOSFET IRF512
Q637,639,641,643	6813A/B,6842A	1855-0549	MOSFET IRF512
Q644	All	1853-0281	XSTR PNP 2N2907A

Table 5-5. HP 6811A/B, 6812A/B, 6813A/B, 6841A, 6842A Inverter Board - continued

Reference Desig.	Applicability	HP Part No.	Description
R601,618,1608,1609	All	0698-8827	RES 1M 1%.125W
R602-605	All	0698-3601	RES 10 5% 2W MO
R614-617	6813A/B,6842A	0698-3601	RES 10 5% 2W MO
R606,609	All	0764-0027	RES 75K 5% 2W MO
R1606,1607	6813A/B,6842A	0764-0027	RES 75K 5% 2W MO
R619-621,649-654	All	0683-2005	20 5% .25W 6174
R656-661,666,668	All	0683-2005	20 5% .25W 6174
R1601-1605,1651,1669	All	0683-2005	20 5% .25W 6174
R667,670,671,673-676	6813A/B,6842A	0683-2005	20 5% .25W 6174
R680-685,687-690	6813A/B,6842A	0683-2005	20 5% .25W 6174
R692,694-698,1652	6813A/B,6842A	0683-2005	20 5% .25W 6174
R622,1617	All	0698-4123	RES 499 1% .125W
R623	All	0757-0429	RES 1.82K 1%
R625	All	0811-1671	RES 2.7 5% 2W PW
R628	6813A/B,6842A	0811-1671	RES 2.7 5% 2W PW
R627	All	0698-8672	RES 243.4 .1%
R631	6813A/B,6842A	0698-8672	RES 243.4 .1%
R632	6811A/B,6812A/B,6841A	0698-0084	RES 2.15K 1%
R632	6813A/B,6842A/B	0698-4196	RES 1.07K 1%
R630,633,1620,1621	6813A/B,6842A	0698-8812	RES-1 1% .125W
R633	6811A/B,6812A/B,6841A	8159-0005	RES-ZERO OHMS
R635,636	All	0757-0435	RES 3.92K 1%
R637,638,643,644	All	0683-2705	RES 27 5% .25W
R639-642	All	0757-0442	RES IOK 1%.125W
R646,663	All	0698-5330	100 2% 2W M06603
R647,648.664,665	All	0683-1005	RES 10 5%.25W
R655,662.672,679	All	0683-1535	RES 15K 5%.25W
R686,691.693,699	6813A/B,6842A	0683-1535	RES 15K 5%.25W
R1610	All	0698-8638	RES 3.16K 5662
R1613,1614	All	0699-0533	RES 4.64K . 1 %
R1615	All	0698-6619	RES 15K.1%
R1618	All	0698-3160	RES 31.6K 1%
R1619	All	0757-0436	RES 4.32K 1%
R1622	All	0757-0346	RES 10 1%.125W
R1625	All	0757-0280	RES 1K 1%.125W
R1626,1627	All	0698-3260	RES 464K 1%
R1628	All	0757-0455	RES 36.5K 1%
R1629	All	0698-3153	RES 3.83K 1%
R1653	All	0757-0440	RES 7.5K 1%
T601,602	All	5080-2371	INVT DRIVER XFMR
T603,604	6813A/B,6842A	5080-2371	INVT DRIVER XFMR
U602	All	1990-1031	OPTO-ISLR 6603
U605,606,610	All	1820-1437	IC SN74LS22IN
U607,609	All	1821-1439	DRIVER-IC
U608	All	5080-2406	PRGMD GAL,INVERT
U619	All	5060-3212	IC LM317T
U620	6813A/B,6842A	5060-3212	IC LM317T
U621	All	1826-0468	IC MC3423PI
W601-603	All	7175-0057	WIRE 22

5 - Replaceable Parts

Table 5-6. Parts List for HP 6811A/B, 6812A/B, 6813A/B, 6841A, 6842A FET Board

Reference Desig.	Applicability	HP Part No.	Description
ELECTRICAL PARTS			
C201	All	0160-7505	CAP 7 uf 5% 200V
C202,206,220,222	All	0180-4132	CAP 6.8uf 35V
C203,218,227	All	0160-4835	CAP 1 uF 10% 50V
C204,205,217,221,242,243	All	0160-5098	CAP .22 uF 10%
C207.209,215,216	6811A/B,6812A/B,6841A	0140-0204	CAP 47 pF 5% 500V
C208.219	6811A/B,6812A/B,6841A	0160-2006	CAP 100 pF 10%
C207-209,215,216,219	6813A/B,6842A	0160-2006	CAP 100 pF 10%
C210,211,213,214	All	0160-6838	CAP 2200 pf IKV
C226,239	All	0160-4791	CAP 10 pF 5% 100V
C228	All	0160-4904	CAP 6800 pF 5%
C229,235-238,240	All	0160-4832	CAP .01 uF 10%
C230	All	0160-4831	CAP 4700 pF 10%
C244,245	All	0160-6806	CAP 1 uF 400V
D201,203,204,206-210	All	1901-0050	DIO-SWITCHING
D202,205	All	1901-1065	DIO-IN4936 PWR
D213-217,220-223	All	1901-0050	DIO-SWITCHING
D224	All	1901-0731	DIO-IN4004/10GO4
E239	All	5080-2359	CABLE
E242	All	5080-2361	CABLE
J200	All	1252-0055	CONN-POST-TP HDR
L201,204,214,215	All	9170-1454	CORE-SHLD-BEAD
L202,203,213,216	6813A/B,6842A	9170-1454	CORE-SHLD-BEAD
L206,207,210,211	All	9170-1510	CORE-MAGNETIC
L205,208,209,212	6813A/B,6842A	9170-1510	CORE-MAGNETIC
Q201,203,222,244	All	5080-2241	FET MATCHED SET
Q202,204,211,233	6813A/B,6842A	5080-2241	FET MATCHED SET
Q251-254	All	1853-0363	D45H5/H8/X45H281
R201,213,214,216,217	All	0699-3196	RES 150 5% 10W
R202	All	0699-0208	RES 1 5% .25W CF
R203	All	0683-8215	RES 820 5% .25W
R204	All	0698-0083	RES 1.96K 1%
R205,209,229,233	All	0683-2005	20 5% .25W 6174
R206,231	6811A/B,6812A/B,6841A	0683-1515	RES 150 5% .25W
R206,231	6813A,6842A	0683-7505	RES 75 5% .25W
R207,232	All	0683-0335	RES 3.3 5% .25W
R208,230	All	0683-3305	RES 33 5% .25W
R210,228	6811A/B,6812A/B,6841A	0683-2015	RES 200 5% .25W
R210,228	6813A/B,6842A	0683-1015	RES 100 5% .25W
R211,212,226,243	All	0683-1535	RES 15K 5% .25W
R220,221,224,225	All	0699-3196	RES 150 5% IOW
R222	All	0811-2556	RES 1.25 1% 4W
R227,248	All	0698-3159	RES 26.IK 1%
R237.239,241	All	0757-0437	RES 4.75K 1%
R242,273-275	All	0757-0437	RES 4.75K 1%
R238,240	All	0757-0280	RES IK 1% .125W
R244	All	0757-0417	RES 562 1% .125W
R245,255	All	0683-1015	RES 100 5% .25W
R246	All	0683-1555	RES 1.5M 5% .25W
R247	6811A/B,6812A/B,6841A	0698-3450	RES 42.2K 1%
R247	6813A/B,6842A	0757-0460	RES 61.9K 1%

Table 5-6. HP 6811A/B, 6812A/B, 6813A/B, 6841A, 6842A FET Board - continued

Reference Desig.	Applicability	HP Part No.	Description
R249	All	0698-3518	RES 7.32K 1%
R250	6811A/B,6812A/B,6841A	0698-3499	RES 40.2K 1%
R250	6813A/B,6842A	0757-0458	RES 51.1K 1%
R251	All	0757-0288	RES 9.09K 1%
R252	All	0698-3225	RES 1.43K 1%
R253	6811A/B,6812A/B,6841A	0698-3136	RES 17.8K 1%
R253	6813A/B,6842A	0757-0446	RES 15K 1%
R254	All	0698-3279	RES 4.99K 1%
R256	6811A/B,6812A,6841A	0698-3439	RES 178 1%.125W
R256	6813A/B,6842A	0698-3432	RES 26.1 1%.125W
R257	All	0757-0316	RES 42.2 1%
R258	All	0683-1035	RES 10K 5%.25W
R260,261,263-265,267	All	0683-8205	RES 82 5%.25W
R262,266	All	0683-1215	RES 120 5%.25W
R268	All	0698-3572	RES 60.4K 1%
R269	All	0698-4121	RES 11.3K 1%
R270	All	0757-0424	RES 1.1K 1%
R271	All	0757-0200	RES 5.62K 1%
R272	All	0757-0442	RES 10K 1%.125W
R285	All	8159-0005	RES-ZERO OHMS
R299	All	0698-3646	RES 12K 5% 2W MO
RV200	All	0837-0442	VARISTOR
T202	All	9100-4350	XFMR-CURRENT
T204	All	06624-80091	XFMR-PULSE
TB201	All	2110-0726	FUSE CLIPS
U201,202	All	1820-8433	IC-PWM IR2110
U203	All	1826-1343	IC-REG TL431CP
U204	All	1826-0138	IC-COM LM339N
VR201	All	1902-1377	DIO-ZNR 6.19 V
W200	All	8150-4697	WIRE 14 WH/GY

Table 5-7. Parts List for HP 6811A/B, 6812A/B, 6813A/B, 6841A, 6842A DC RAIL Board

Reference Desig.	Applicability	HP Part No.	Description
ELECTRICAL PARTS			
C400-405	All	0160-7640	C-F 330pF 1600V
C409,411,413,419,454,475	All	0180-4129	CAP 1uf 35V
C416	All	0160-4834	CAP .047UF 10%
C417	All	0180-3458	CAP 4700UF 50V
C418	All	0180-4405	CAP 470 uf 50V
C425, 427-429, 33-442, 449, 453, 465-468	All	0160-5422	CAP .047 UF 20%
C426,444,473	All	0180-4136	CAP 10uf 20V
C432	All	0150-0050	CAP 1000PF +80
C447,451,495,498	All	0160-5098	CAP .22UF 10%
C448	All	0160-4799	CAP 2.2PF
C452	All	0160-4808	CAP 470PF 100V
C455	All	0160-4831	CAP 4700PF 10%
C456	All	0160-4823	CAP 820PF 5%

5 - Replaceable Parts

Table 5-7. HP 6811A/B, 6812A/B, 6813A/B, 6841A, 6842A DC RAIL Board - continued

Reference Desig.	Applicability	HP Part No.	Description
ELECTRICAL PARTS			
C459	All	0160-4810	CAP 330PF 5%
C462,464	All	0160-4797	CAP 3.3PF
C463	All	0160-4807	CAP 33PF 5% 100V
C476,480	All	0160-4795	CAP 4.7PF
C477,478	All	0160-4787	C-F 22PF 5% 100V
C481,485	All	0160-4904	CAP 6800PF 5%
C482,483,492	All	0160-4835	CAP .1UF 10% 50V
C484,489	All	0160-4791	CAP 10PF 5% 100V
C491	All	0180-4131	CAP 4.7uf 35 V
C493	All	0160-4805	CAP 47PF 5% 100V
C494	All	0160-4822	CAP 1000PF 5%
C496,497	All	0160-4824	CAP 680pf 100v
D400-407	All	1901-1543	DIODE
D416-419	All	1901-0731	DIODE-1N4004/10G04
D420,475	All	1901-1098	DIODE-1N4150
D423	All	1902-0951	DIODE-ZENER
DS400	All	1990-0517	LED-VISIBLE
E430-1,2,3,4	All	1251-5613	CONN-SGL CONN
E432	All	5080-2354	CABLE
E454	All	1251-0600	CONTACT-CONN M
HS400, 402-404, 406, 407	All	1205-0298	HEAT SINK
J400	All	1252-2503	CONN-POST-TP-HDR
J436	All	1251-8606	CONN-POST-TP-HDR
J444	All	1251-5980	CONN-UTIL
J445	All	1252-1707	CONN-POST-TP-PST
Q450,491	All	1855-0727	MOSFET 2N7000
Q475,476	All	1854-0477	XSTR NPN 2N2222A
R1408	All	0698-3499	RES 40.2K 1%
R1409	All	0757-0465	RES 100K 1%
R400,401,406,407	All	0699-3196	RES 150 5% 10W
R403,404	All	0811-1914	RES 5K 5% 10W PW
R408,410	All	0811-1708	RES 7K 5% 5W 5PWI
R412	All	0811-1826	RES .05 10% 3W
R413	All	0812-0050	RES 3K 5% 5W PW
R414,425,449	All	0698-3279	RES 4.99K 1%
R415,420	All	0698-8672	RES 243.4 .1%
R416,419,422	All	0757-0281	RES 2.74K 1%
R417, 418, 421, 469, 407, 1417, 1418	All	8159-0005	RES-ZERO OHMS
R423	All	0698-3637	RES 820 5% 2W MO
R424,432,493	All	0757-0199	RES 21.5K 1%
R426, 427, 429, 451, 459, 471, 1401-1405	All	0698-3155	RES 4.64K 1%
R428,463	All	0757-0446	RES 15K 1% .125W
R430	All	0698-8827	RES 1M 1% .125W
R431	All	0698-3159	RES 26.1K 1%
R433	All	0698-8807	RES 39K .1%
R434,435	All	0698-6369	RES 1M .1% .25W

Table 5-7. HP 6811A/B, 6812A/B, 6813A/B, 6841A, 6842A DC RAIL Board - continued

Reference Desig.	Applicability	HP Part No.	Description
ELECTRICAL PARTS			
R436	All	0698-6614	RES 7.5K .1%
R437	All	0699-0721	RES 33K .1%
R439	All	0698-6977	RES 30K .1% .125
R440, 444, 450, 458, 1415	All	0757-0419	RES 681 1% .125W
R441	All	0757-0420	RES 750 1% .125W
R445	All	0698-6376	RES 200K .1%
R446	All	0698-0085	RES 2.61K 1%
R447	All	0698-6392	RES 22K .1% .125W
R448	All	0698-3700	RES 715 1% .125W
R452	All	0683-2255	RES 2.2M 5% .25W
R453	All	0698-0083	RES 1.96K 1%
R454	All	0699-0486	RES 2K .1% .1W F
R456, 468, 470, 499, 1411	All	0698-3430	RES 21.5 1%
R457	All	0698-3486	RES 232 1% .125W
R460	All	0698-8816	RES 2.15 1%
R462	All	0757-0462	RES 75K 1% .125W
R464	All	0757-0274	RES 1.21K 1%
R465	All	0757-0467	RES 121K 1%
R467	All	0698-4479	RES 14K 1% .125W
R475,476	All	0699-0070	RES 3.16M 1%
R477	All	0757-0280	RES 1K 1% .125W
R478, 482, 484, 485	All	0757-0472	RES 200K 1%
R479, 481, 491	All	0757-0442	RES 10K 1% .125W
R480, 487, 1410	All	0757-0407	RES 200 1% .125W
R483,489	All	0757-0434	RES 3.65K 1%
R486,488	All	0698-4486	RES 24.9K 1%
R490	All	0698-4446	RES 267 1% .125W
R492	All	0757-0273	RES 3.01K 1%
R494,496	All	0757-0427	RES 1.5K 1%
R495,497	All	0757-0401	RES 100 1% .125W
REF U463	All	1200-0639	SKT-IC 20-CONT
T491	All	06624-80091	XFMR-PULSE
TP401-404	All	1251-5380	POST-TP-HDR 6603
U416	All	5060-3212	ASSY-HS 317T
U417	All	1826-0122	IC 7805/340T-5
U418	All	1826-0527	IC LM337T
U423	All	1826-2341	IC-REG TL7702BCP
U424	All	1826-0138	IC-COM LM339N
U433,434	All	1990-0732	OPTO-ISOLATOR
U435	All	1990-1502	OPTO-ISOLATOR
U436	All	1990-0429	OPTO-ISOLATOR
U447,475	All	1826-1533	IC 34072
U449	All	1826-1437	IC
U462	All	1826-0065	IC LM311
U463	All	5080-2405	PRGMD GAL, DIR
U464	All	1820-3673	IC MM74HC123N
U491	All	1826-2343	IC-REG TL598CN
W400	All	7175-0057	WIRE 22

5 - Replaceable Parts

Table 5-8. Parts List for HP 6811A/B, 6812A/B, 6813A/B, 6841A, 6842A Output Board

Reference Desig.	Applicability	HP Part No.	Description
ELECTRICAL PARTS			
C500-503	All	0180-4649	CAP 2500 uf 300V
C506	All	0160-7197	CAP 0.33 uF 630 V
C508-516	All	0160-7640	C-F 330 pF 1600V
C533,534,541,544,	All	0160-5422	CAP .047 uF 20%
C540,543	All	0160-4803	CAP 68 pF 5% IOOV
C542,554	All	0160-4795	CAP 4.7 pF
C545,547	All	0160-4814	CAP 150 pF 5%
C546	All	0160-4825	CAP 560 uf 100V
C548,549,575,576	All	0160-5422	CAP .047 uF 20%
C550	6811A/B	0160-4824	CAP 680 pF
C550	6812A/B,6813A/B, 6841A, 6842A	0160-4809	CAP 390 pF 100V
C553,555	All	0160-4789	CAP 15 pF 5% 100V
C556,557	All	0160-4819	CAP 2200 pF 5%
C564,565	All	0180-4136	CAP 10uf 20V
C568,569	All	0160-7934	2 uF 300 vac 2%
C570	All	0160-4918	CAP .022 uf 10%
C571	All	0160-4835	CAP 1 uF 10% 50V
C578,579,580	All	0160-5422	CAP 0.047 uF 20%
D501,502	All	1901-1098	DIO-IN4150
E525	All	0813-80005	CABLE
J524	All	1252-1052	DIN-CONN-MALE
J526,527	All	1251-7616	CONN-UTIL MT-LK
K500	See Rev C assembly replacement parts at end of table		
K501	All	0490-1405	RELAY 2C 12 VDC
K502,503	All	0490-1961	RELAY 1C 12VDC
L500,501	6811A/B	06811-80004	CHOKE
L500,503	6812A/B,6813A/B, 6841A,6842A	5080-2331	CHOKE
L504	6811A/B	06811-80005	CHOKE
L504,505	6812A/B,6813A/B, 6841A,6842A	5080-2332	CHOKE
L507,508	All	5080-2330	INDUCTOR
L509	All	5080-2368	INDUCTOR-RESON
L512,513	All	9135-0481	INDUCTOR-CM
L514	All	5080-2461	INDUCTOR
P527	All	5080-2351	CABLE
P537	All	5080-2346	CABLE
P544	All	5080-2363	CABLE
P545	All	5080-2350	CABLE
Q501,502	All	1855-0665	MOSFET RFP 2N12L
R502	All	0698-3547	RES 1 5%.5W CC
R503,565,576,577	All	0811-1832	RES 5 1% 3W PW
R506,507,512-515	All	0683-1065	RES IOM 5% .25W
R508,509,566,567	All	0699-1060	RES .05 1% 3W

Table 5-8. HP 6811A/B, 6812A/B, 6813A/B, 6841A, 6842A Output Board - continued

Reference Desig.	Applicability	HP Part No.	Description
R510	6811A/B	06811-80006	RES SHUNT W/PIN
R510	6812A/B,6813A/B, 6841A,6842A	5080-2383	RES SHUNT W/PIN
R511,543,549	All	0699-0222	RES 10.5K .1%
R520,R523	All	0698-3152	RES 3.48K 1%
R521,522	All	0757-0414	RES 432 1% .125W
R529,R530	All	0698-6414	RES IK.1%.1W F
R531,536,539-542	All	0699-1743	RES 345K .1%
R532,533	All	0699-1741	RES 5.657K.1%
R535	All	0699-4307	RESISTOR-FIXED
R537,544-546,595,596	All	0757-0401	RES 100 1%.125W
R547	6811A/B	0757-1100	RES 600 1% .125w
R547	6812A/B,6813A/B, 6841A,6842A	0698-4463	RES 845 1%.125W
R500,501,592,593	All	0698-3260	RES 464K 1%
R550,555,558,559	All	0698-8826	RES 825K 1%
R551,554	All	0757-0279	RES 3.16K 1%
R552,553	All	0698-3156	RES 14.7K 1%
R560	All	0698-OG64	RES 9.31K 1%
R568	All	0698-3609	RES 22 5% 2W MO
R571,572	All	0699-3420	RES 56K 5% 5W
R573,574	All	0698-3279	RES 4.99K 1% .125W
R575	All	0698-4446	RES 267 1% .125W
R569	All	0757-0407	RES 200 1% .125W
R578	All	0698-3430	RES 21.5 1%
R579,580	All	0698-8812	RES 1 1%.125W F
R581	All	0683-0475	RES 4.7 5% .25W
R584-591	All	0811-1810	RES 3.6K 5% 3W
R594	All	0683-1015	RES 100 5% .25W
RT501	All	0837-0397	THERMISTOR
TB552	All	0360-2578	BARRIER BLOCK
TP500	All	1250-1918	TEST JACK
U500	All	1826-1081	IC LF411A
U502,506	All	1826-1135	IC OP-27
U503	All	1826-0412	IC LM393N
W501	All	7175-0057	WIRE 2
NOTE: The following parts are used only in Output Filter assemblies Revision C and below.			
K500	6812A/B,6813A/B, 6841A,6842A	5063-3494	RELAY-ASSEMBLY
L510,511	6812A/B,6813A/B, 6841A,6842A	9140-1743	CHOKe 82uH MOLDED
R500,501	6812A/B,6813A/B, 6841A,6842A	0698-3260	RES 464k 1%
R503	6812A/B,6813A/B, 6841A,6842A	0812-0047	RES 5 5% 5W PW
R584-591	6812A/B,6813A/B, 6841A,6842A	0811-1810	RES 3.6K 5% 3W

5 - Replaceable Parts

Table 5-9. Parts List for HP 6811A/B, 6812A/B, 6813A/B, 6841A, 6842A Control Board

Reference Desig.	Applicability	HP Part No.	Description
U985	All	5080-2410	Programmed GAL Freq
U988	All	5080-2408	programmed GAL Status
U991	All	5080-2409	Programmed GAL Protect
U1801	All	5080-2407	Programmed GAL PWM/RLY

Table 5-10. Parts List for HP 6811A/B, 6812A/B, 6813A/B, 6841A, 6842A Front Panel

Reference Desig.	Applicability	HP Part No.	Description
G1, G2	All	0960-0912	RPG
U004	All	5080-2384	Programmed ROM front panel

Table 5-11. Parts List for HP 6811A/B, 6812A/B, 6813A/B, 6841A, 6842A DSP Board

Reference Desig.	Applicability	HP Part No.	Description
U714	6841A,6842A	5080-2421	Programmed GAL
U715	6841A,6842A	5080-2422	Programmed GAL
U716	6841A,6842A	5080-2423	Programmed GAL
U734	6811A,6812A,6813A	5080-2411	Programmed ROM
U734	6811B,6812B,6813B,6841A,6842A	5080-2424	Programmed ROM
U735	6811A,6812A,6813A	5080-2412	Programmed ROM
U735	6811B,6812B,6813B,6841A,6842A	5080-2425	Programmed ROM

Table 5-12. Parts List for HP 6811A/B, 6812A/B, 6813A/B, 6841A, 6842A Thermistor Board

Reference Desig.	Applicability	HP Part No.	Description
RT1 3004	All	0837-0397	Thermistor Cyl.
	All	5080-2367	Cable

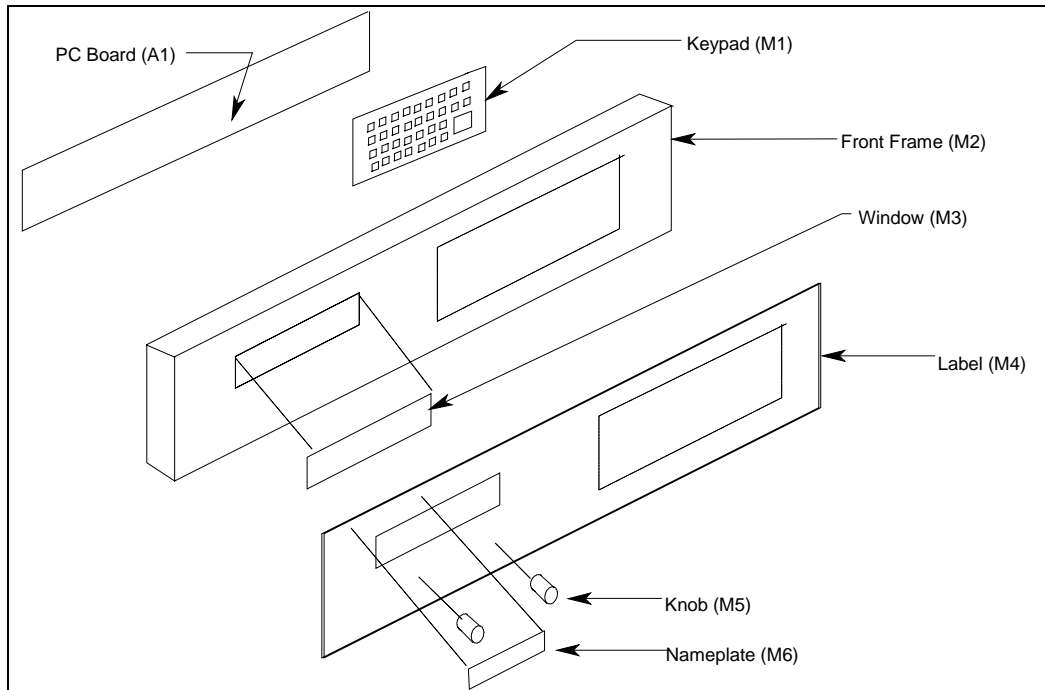

Figure 5-1. Front Panel Components (see Table 5-1)

Diagrams

Introduction

This chapter contains drawings and diagrams for troubleshooting and maintaining the HP Series 6611A/B 6612A/B 6613A/B AC Power Source/Analyzers, and HP Series 6841A/6842A/6843A Harmonic Flicker Test Systems. Unless otherwise specified, a drawing or diagram applies to all models of the series (see general schematic note #1). Wiring connections to external equipment are shown in the ac source User's Guide.

General Schematic Notes

Not all components or values shown on the schematic apply to all ac source models. The parts lists in chapter 5 contains information about components that are model-specific.

All resistors are in ohms 1%, 1/8 W, unless otherwise specified.

All capacitors are in microfarads unless otherwise specified.

Signal lines that are terminated by flags continue on other sheets and may go to other locations on the same sheet. For example: CVPROG (SH.2 8C) on sheet 2 location 8C) the same location All resistors are in ohms 1%, 1/8 W, unless otherwise specified.

All resistors are in ohms 1%, 1/8 W, unless otherwise specified.

Unless otherwise noted, bias connections to integrated-circuit packages are as follows:

	<u>Common</u>	<u>5 V</u>
14-pin packages	pin 7	pin 14
16-pin packages	pin 8	pin 16
20-pin packages	pin 10	pin 20

Figure 6-1. Interconnect Diagram

Figure 6-2. Front Panel Assembly, Component Locations

6 - Diagrams

Figure 6-3. Front Panel Assembly, Schematic Diagram (sheet 1 of 2)

Figure 6-3. Front Panel Assembly, Schematic Diagram (sheet 2 of 2)

Figure 6-4. HP-IB Assembly, Component Locations

Figure 6-5. HP-IB Assembly, Schematic Diagram

Figure 6-6. FET Assembly, Component Locations

Figure 6-7. FET Assembly, Schematic Diagram

6 - Diagrams

Figure 6-8. AC Input Assembly, Component Locations

Figure 6-9. AC Input Assembly, Schematic Diagram

6 - Diagrams

Figure 6-10. DC Rail/Diode Assembly, Component Locations (sheet 1 of 2)

Figure 6-10. DC Rail/Diode Assembly, Component Locations (sheet 2 of 2)

6 - Diagrams

Figure 6-11. DC Rail/Diode Assembly, Schematic Diagram (sheet 1 of 3)

Figure 6-11. DC Rail/Diode Assembly, Schematic Diagram (sheet 2 of 3)

6 - Diagrams

Figure 6-11. DC Rail/Diode Assembly, Schematic Diagram (sheet 3 of 3)

Figure 6-12. Bias Assembly, Component Locations

6 - Diagrams

Figure 6-13. Bias Assembly, Schematic Diagram (sheet 1 of 2)

Figure 6-13. Bias Assembly, Schematic Diagram (sheet 2 of 2)

Figure 6-14. Inverter Assembly, Component Locations

Figure 6-15. Inverter Assembly, Schematic Diagram (sheet 1 of 4)

6 - Diagrams

Figure 6-15. Inverter Assembly, Schematic Diagram (sheet 2 of 4)

Figure 6-15. Inverter Assembly, Schematic Diagram (sheet 3 of 4)

6 - Diagrams

Figure 6-15. Inverter Assembly, Schematic Diagram (sheet 4 of 4)

Figure 6-16. DSP Assembly, Component Locations (sheet 1 of 2)

6 - Diagrams

Figure 6-16. DSP Assembly, Component Locations (sheet 2 of 2)

Figure 6-17. DSP Assembly, Schematic Diagram (sheet 1 of 10)

6 - Diagrams

Figure 6-17. DSP Assembly, Schematic Diagram (sheet 2 of 10)

Figure 6-17. DSP Assembly, Schematic Diagram (sheet 3 of 10)

6 - Diagrams

Figure 6-17. DSP Assembly, Schematic Diagram (sheet 4 of 10)

Figure 6-17. DSP Assembly, Schematic Diagram (sheet 5 of 10)

6 - Diagrams

Figure 6-17. DSP Assembly, Schematic Diagram (sheet 6 of 10)

Figure 6-17. DSP Assembly, Schematic Diagram (sheet 7 of 10)

6 - Diagrams

Figure 6-17. DSP Assembly, Schematic Diagram (sheet 8 of 10)

Figure 6-17. DSP Assembly, Schematic Diagram (sheet 9 of 10)

6 - Diagrams

Figure 6-17. DSP Assembly, Schematic Diagram (sheet 10 of 10)

Figure 6-18. Control Board, Component Locations (sheet 1 of 2)

6 - Diagrams

Figure 6-18. Control Board, Component Locations (sheet 2 of 2)

Figure 6-19. Control Assembly, Schematic Diagram (sheet 1 of 7)

6 - Diagrams

Figure 6-19. Control Assembly, Schematic Diagram (sheet 2 of 7)

Figure 6-19. Control Assembly, Schematic Diagram (sheet 3 of 7)

6 - Diagrams

Figure 6-19. Control Assembly, Schematic Diagram (sheet 4 of 7)

Figure 6-19. Control Assembly, Schematic Diagram (sheet 5 of 7)

6 - Diagrams

Figure 6-19. Control Assembly, Schematic Diagram (sheet 6 of 7)

Figure 6-19. Control Assembly, Schematic Diagram (sheet 7 of 7)

Figure 6-20. Output Board, Component Locations

Figure 6-21. Output Assembly, Schematic Diagram (sheet 1 of 4)

6 - Diagrams

Figure 6-21. Output Assembly, Schematic Diagram (sheet 2 of 4)

Figure 6-21. Output Assembly, Schematic Diagram (sheet 3 of 4)

6 - Diagrams

Figure 6-21. Output Assembly, Schematic Diagram (sheet 4 of 4)

Figure 6-22. Trigger Board, Component Locations

Figure 6-23. Trigger Assembly, Schematic Diagram

Figure 6-24. Thermistor Assembly, Component Locations

Figure 6-25. Thermistor Assembly, Schematic Diagram

Figure 6-26. Transformer Assembly, Component Locations

Figure 6-27. Transformer Assembly, Schematic Diagram

Index

—C—

- cal denied, 47
- calibration, 47
 - post repair, 47
- change page, 10
- component locations
 - AC Input assembly, 76
 - bias assembly, 83
 - control board, 103
 - dc rail/diode assembly, 78
 - DSP assembly, 91
 - FET assembly, 74
 - front panel assembly, 69
 - HP-IB assembly, 72
 - inverter assembly, 86
 - output board, 112
 - thermistor assembly, 119
 - transformer assembly, 119
 - trigger board, 117
- constant voltage load effect, 13
- constant voltage source effect, 14
- constant voltage tests, 12
- copyrights, 4
- current monitor resistor, 12

—D—

- dc readback accuracy, 15
- dc voltage programming, 15
- description
 - A1 front panel, 19
 - A10 Control assembly, 22
 - A11 Trigger assembly, 22
 - A3 FET assembly, 20
 - A4 AC Input assembly, 20
 - A5 DC Rail assembly, 20
 - A6 Bias assembly, 21
 - A7 Inverter assembly, 21
 - A8 Digital signal processing assembly, 21
 - A9 Output/Filter assembly, 21
 - HP-IB assembly, 20
 - RS-232 assembly, 20
- disassembly, 48
 - AC FET assembly, 50
 - AC Input board, 50
 - Bias board, 51
 - DC rail board, 50
 - DSP/Control board, 51
 - front panel, 49
 - HP-IB/RS-232 board, 50
 - Inverter assembly, 51
 - output board, 52
 - tools, 49

trigger board, 52

—E—

- electrostatic discharge, 10
- error codes, 24, 25
- ESD, 10

—F—

- firmware revisions, 10
- frequency accuracy, 15

—H—

- harmonic distortion, 15
- hazardous voltages, 9
- hints, 23

—I—

- identification, 10
- inhibit calibration, 47
- initialization, 46
- interconnect diagram, 68

—J—

- J307 voltages, 41, 42

—M—

- manual revisions, 10

—N—

- notice, 4

—O—

- overall
 - troubleshooting, 26

—P—

- power-on self-test, 24

—R—

- readback accuracy, 13
- replaceable parts
 - ac FET board, 60
 - ac input board, 56
 - bias board, 57

- control board, 66
- dc rail board, 61, 62, 63
- DSP board, 66
- front panel board, 66
- inverter board, 58
- main assemblies, 54
- output board, 64
- thermistor board, 66

revisions, 10

rms current accuracy, 14

ROM upgrade, 46

run-time, 25

—S—

safety

- considerations, 9
- summary, 3

schematic diagrams

- AC input assembly, 77
- bias assembly, 84
- control board, 105
- dc rail/diode assembly, 80
- DSP assembly, 93
- FET assembly, 75
- front panel assembly, 70
- HP-IB assembly, 73
- inverter assembly, 87
- output board, 113
- thermistor assembly, 119
- transformer assembly, 119
- trigger board, 118

- schematic notes, 67
- self-test, 24
- serial number, 10

—T—

test equipment

- troubleshooting, 23
- verification, 11

test record

- HP 6811A, 16
- HP 6812A, 17
- HP 6813A, 18
- HP 6841A, 17
- HP 6842A, 18

troubleshooting

- Bias assembly, 33
- Control assembly, 40
- DSP board, 40
- FET board, 29
- front panel, 28
- Inverter assembly, 35
- Output/Filter/Relay assembly, 43
- Rail assembly, 31
- RS-232, 28
- Trigger/BNC board, 44

troubleshooting HP-IBboard, 28

—V—

voltage programming, 13

HP Sales and Support Offices

For more information, call your local HP Sales Office listed in the telephone directory white pages. Ask for the Electronic Instruments Department.

Or contact:

United States:

Hewlett-Packard Company
4 Choke Cherry Road
Rockville, MD 20850
(301) 670-4300

Hewlett-Packard Company
5201 Tollview Drive
Rolling Meadows, IL 60008
(312) 255-9800

Hewlett-Packard Company
5161 Lankershim Blvd.
No. Hollywood, CA 91601
(818) 505-5600

Hewlett-Packard Company
2015 South Park Place
Atlanta, GA 30339
(404) 955-1500

Canada:

Hewlett-Packard Ltd.
6877 Goreway Drive
Mississauga, Ontario L4V1M8
(416) 678-9430

Australia/New Zealand:

Hewlett-Packard Australia Ltd.
3141 Joseph Street
Blackburn, Victoria 3130
Melbourne, Australia
(03) 895-2895

Europe:

European Headquarters
Hewlett-Packard S.A.
150, Route du Nant d'Avril
1217 Meyrin 2
Geneva -- Switzerland
41/22 780-8111

Far East:

Hewlett-Packard Asia Ltd.
89 Queensway
Central, Hong Kong
(5) 8487777

Japan:

Yokogawa-Hewlett-Packard Ltd.
15-7, Nishi Shinjuku 4 Chome
Shinjuku-ku, Tokyo 160, Japan
(03) 5371-1351

Latin America:

Latin American Region Headquarters
Monte Pelvoux Nbr. 111
Lomas De Chapultepec
11000 Mexico, D.F. Mexico
(525) 202 0155

Middle East and Africa:

Geneva -- Switzerland
41/22 780-7111

For all other areas:

Hewlett-Packard Company
Intercontinental Headquarters
3495 Deer Creek Road
Palo Alto, CA 94304
U.S.A.

Manual Updates

The following updates have been made to this manual since the print revision indicated on the title page.

11/99

The instrument identification section on page 10 has been updated.

Sheet 1 of Figure 4-1 has been updated.

Sheet 2 of Figure 4-7 has been updated.

A Slow-Start Procedure has been added to the end of the A7 Inverter Assembly troubleshooting section.

Part number corrections have been made in Table 5-1, Table 5-10, and Table 5-11.